

MANUAL USE AND MAINTENANCE

SILENCED ROTARY SCREW COMPRESSOR UNITS

HP 40 - 50 - 60 KW 30 - 37 - 45
HP 40 - 50 - 60 (VSD*) KW 30 - 37 - 45 (VSD*)

(VSD *): Variable speed compressors

Code	
9828093271	01
Edition 10/2019	

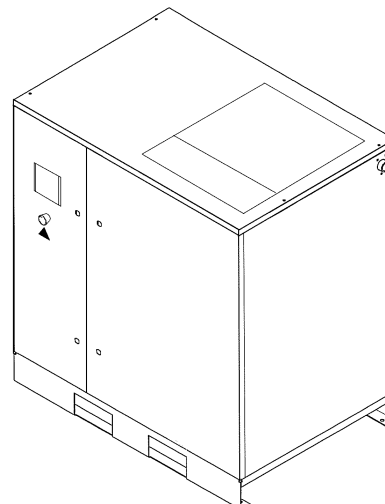
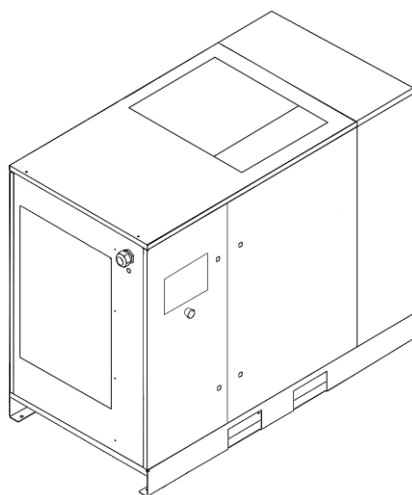

READ THIS MANUAL CAREFULLY BEFORE ANY OPERATION ON THE COMPRESSOR UNIT.



WARNING: CAPACITORS INSIDE INVERTER MAY REMAIN CHARGED FOR 15 MINUTES AFTER THE UNIT HAS BEEN DISCONNECTED FROM MAIN SUPPLY.

WAIT AT LEAST 15 MINUTES AFTER POWER SUPPLY HAS BEEN REMOVED BEFORE PERFORM SERVICE OR REPAIR TO AVOID DEATH OR SERIOUS INJURY.

CONTENTS	
PART A: INFORMATION FOR THE USER	17.0 SCRAPPING THE UNIT
1.0 GENERAL FEATURES	18.0 LIST OF SPARE PARTS FOR ROUTINE MAINTENANCE
2.0 INTENDED USE	19.0 TROUBLE-SHOOTING AND EMERGENCY REMEDIES
3.0 OPERATION	
4.0 GENERAL SAFETY STANDARDS	PART B: INFORMATION RESERVED FOR TECHNICALLY SKILLED PERSONNEL
5.0 DESCRIPTION OF DANGER WARNINGS	20.0 STARTING UP
6.0 DANGER ZONES	21.0 GENERAL ORDINARY MAINTENANCE REQUIRES TRAINED PERSONNEL
7.0 SAFETY DEVICES	22.0 CHANGING THE OIL
8.0 POSITION OF PLATES	23.0 CHANGING THE OIL FILTER AND OIL SEPARATOR FILTER
9.0 COMPRESSOR ROOM	24.0 MOTOR BEARINGS LUBRICATION
10.0 TRANSPORT AND HANDLING	25.0 OLEOPNEUMATIC DIAGRAM
11.0 UNPACKING	26.0 CALIBRATION FOR DRYER
12.0 INSTALLATION	27.0 "VSD" VARIABLE SPEED
13.0 DIMENSIONS AND TECHNICAL DATA	
14.0 MACHINE DESCRIPTION	IMPORTANT: A COPY OF THE WIRING DIAGRAMS CAN BE FOUND IN THE ELECTRIC CABINET OF COMPRESSOR.
14.1 General layout	
14.2 Command and control panel	
14.3 Swipe controller for fix speed units	
14.4 Swipe+ controller for variable Speed units	
14.5 Touch controller as options for Fix Speed and Variable Speed	
14.6 Web Server connection	
15.0 ORDINARY MAINTENANCE TO BE DONE BY THE USER	
16.0 PERIODS OF INACTIVITY	

MACHINE AND MANUFACTURER IDENTIFICATION DATA

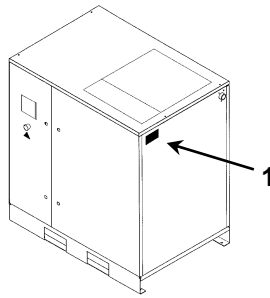

1) Position of the identification plate

ADDRESSES OF ASSISTANCE CENTRES

In the event of breakdown or malfunction of the machine, switch it off and do not tamper with it. If repairs are needed, apply only to a technical assistance centre approved by the manufacturer and insist on the use of original spare parts. Failure to comply with the above may endanger the safety of the machine.

INTRODUCTION

Keep this manual with care for future consultation; the use and maintenance manual is an integral part of the machine. Read this manual carefully before carrying out any work on the compressor unit.

The installation of the compressor unit and all operations involving it must be performed in conformity with the regulations in force concerning electric plants and personal safety.

CHARACTERISTICS AND SAFETY PRECAUTIONS



MACHINE WITH AUTOMATIC START

Lock Out – Tag Out (LOTO): Open the power isolating switch and lock it with a personal lock. Tag the power isolating switch with the name of the service technician.



BEFORE REMOVING THE PROTECTIVE GUARDS TO CARRY OUT ANY MAINTENANCE ON THE MACHINE, SWITCH OFF THE ELECTRIC POWER SUPPLY AND DISCHARGE THE RESIDUAL PRESSURE INSIDE THE UNIT.

ALL MAINTENANCE ON ELECTRICAL PARTS, MUST BE PERFORMED BY PROFESSIONALLY SKILLED PERSONNEL.

THIS MACHINE IS NOT SUITABLE FOR EXTERNAL INSTALLATION

THIS MACHINE CORRESPONDS TO THE ESSENTIAL SAFETY REQUIREMENTS FORESEEN FROM THE EUROPEAN STANDARD (2006/42 CE).

THE LUBRICATING LIQUIDS AND OTHER EVENTUAL FLUIDS MUST NOT BE DISCHARGED IN THE ENVIRONMENT. THESE POLLUTING AND HAZARDOUS PRODUCTS MUST COMPULSORY BE DISPOSED BY CHARGING AUTHORISED AND SPECIALISED FIRMS ACCORDING TO THE DIFFERENT TYPOLOGY OF PRODUCT. DIFFERENTIATE THE COMPRESSOR COMPONENTS ACCORDING TO THE DIFFERENT CONSTRUCTION MATERIALS (PLASTIC, COPPER, IRON, OIL FILTER, AIR FILTER ECC...)

The manufacturer does not accept responsibility for damage caused as a result of negligence or failure to abide by the instructions given above.

SAFETY VALVE:

The safety valves of the oil receiver must be checked every year and replaced in accordance with legislation in force.

NOT RESPECTING THE ABOVE MENTIONED PRESCRIPTION CAN RESULT IN AIR RECEIVER BURSTING HAZARD.

The manufacturer does not accept responsibility for damage caused as a result of negligence or failure to abide by the instructions given above.

1.0 GENERAL CHARACTERISTICS

The compressor units use single-stage screw rotary air compressors with oil injection.
The system is self-bearing and does not require bolts or other devices to anchor it to the floor.
The unit is completely assembled in the factory; the necessary connections for setting it up are:

- connection to the power mains (see installation chapter)
- connection to the compressed air network (see installation chapter)

2.0 INTENDED USE

The compressor has been built to supply compressed air for industrial use.

The machine cannot be used in premises where there is a risk of fire explosion or where work is carried out which releases substances into the environment which are dangerous with regard to safety (for example: solvents, inflammable vapours, alcohol, etc.).

In particular the appliance cannot be used to produce air to be breathed by humans or used on direct contact with foodstuffs. These uses are allowed if the compressed air produced is filtered by means of a suitable filtering system (Consult the manufacturer for these special uses.) This appliance must be used only for the purpose for which it was specifically designed.

All other uses are to be considered incorrect and therefore unreasonable.

The Manufacturer cannot be held responsible for any damage resulting from improper, incorrect or unreasonable use.

3.0 OPERATION

3.1 OPERATION FOR COMPRESSOR

The electric motor and the compressor unit are coupled by means of a gear transmission.

The compressor unit takes in the outside air through the suction valve. The air taken in is filtered by the cartridge fitted upstream from the suction valve. Inside the compressor unit, the air and the lubricating oil are compressed and sent to the oil separating tank where the oil is separated from the compressed air; the air is then filtered again by the oil separating cartridge to reduce the amount of suspended oil particles to a minimum. At this point the two flows (of oil and air) are sent to two separate coolers where they are cooled, using a flow of air taken from the environment by a special fan inside the machine.

The cooled oil returns to the reclaiming, and the compressed air leaves the machine via the outlet.

3.2 OPERATION FOR DRYER

Dryer operation is described below. The gaseous refrigerant coming from the evaporator (4) is sucked by the refrigeration compressor (1) and it is pumped into the condenser (2). This one allows its condensation, eventually with the help of the fan (3); the condensed refrigerant passes through the dewatering filter (8) and it expands through the capillary tube (7) and goes back to the evaporator where it produces the refrigerating effect.

Due to the heat exchange with the compressed air which passes through the evaporator against the stream, the refrigerant evaporates and goes back to the compressor for a new cycle. The circuit is equipped with a bypass system for the refrigerant; this intervenes to adjust the available refrigerating capacity to the actual cooling load. This is achieved by injecting hot gas under the control of the valve (9): this valve keeps constant the pressure of the refrigerant in the evaporator and therefore also the dew point never decreases below 0 °C in order to prevent the condensate from freezing inside the evaporator.

The drier runs completely automatically; it is calibrated in the factory for a dew point of 5 °C and therefore no further calibrations are required.

DRYER FLOW DIAGRAM

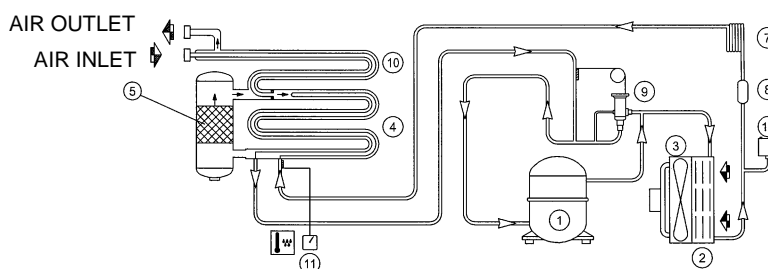

4.0 GENERAL SAFETY STANDARDS

The appliance may be used only by specially trained and authorized personnel.

Any tampering with the machine or alterations not approved beforehand by the Manufacturer relieve the latter of responsibility for any damage resulting from the above actions.









The removal of or tampering with the safety devices constitutes a violation of the European Standards on safety.

ENSURE THAT THERE ARE DISCONNECTOR SWITCH AND FUSES UPSTREAM THE MACHINE. FOR DETAILS (SIZE AND TYPE) SEE WIRING/SERVICE DIAGRAM.



ALL WORK ON THE ELECTRIC PLANT, HOWEVER SLIGHT, MUST BE CARRIED OUT BY PROFESSIONALLY SKILLED PERSONNEL.

5.0 DESCRIPTION OF DANGER SIGNALS

	1) FLUID EJECTION		6) HOT PARTS
	2) DANGEROUS ELECTRIC VOLTAGE		8) MOVING PARTS
	3) AIR NOT FIT FOR BREATHING		9) MACHINE WITH AUTOMATIC START
	4) NOISE		
	5) HIGH PRESSURE		

5.1 DESCRIPTION OF COMPULSORY SIGNALS

	11) READ THE USE AND MAINTENANCE INSTRUCTIONS		
---	---	--	--

6.0 DANGERS ZONES

6.1 DANGERS ZONES FOR COMPRESSOR UNIT

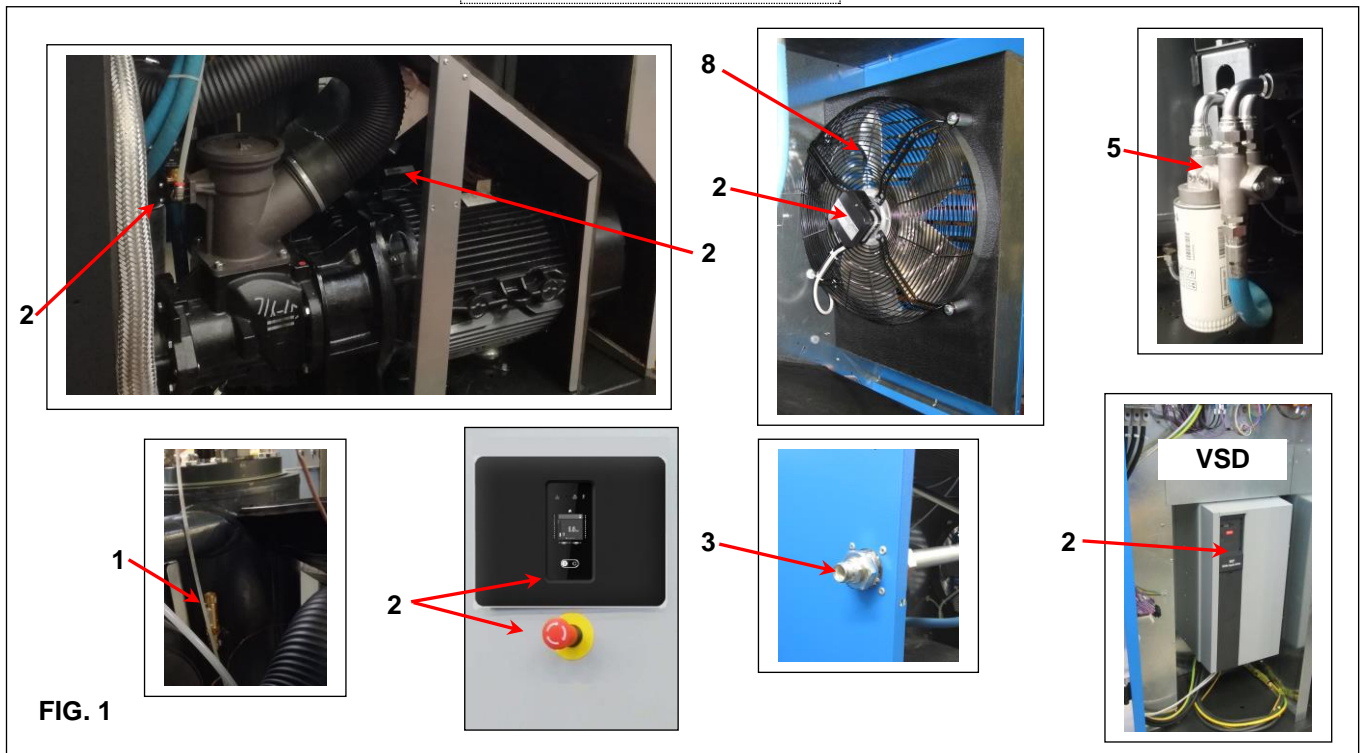
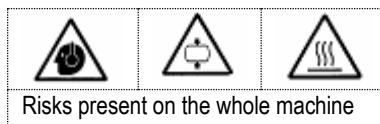

6.2 DANGERS ZONES FOR DRYER UNIT

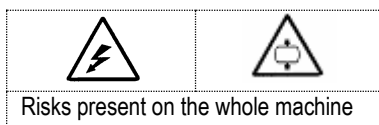
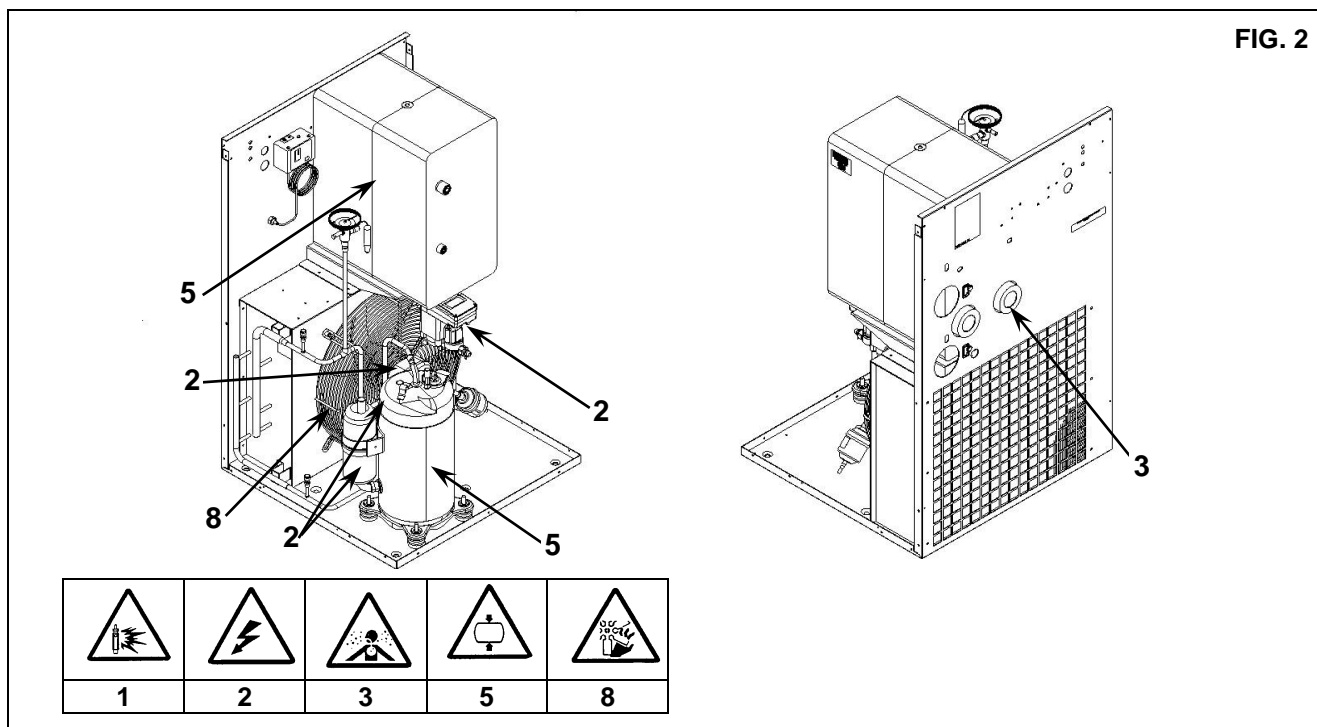

FIG. 2



7.0 SAFETY DEVICES

7.1 SAFETY DEVICES FOR SCREW COMPRESSOR (Fig. 3)

1) Safety screws	4) Emergency stop button with mechanical seal and rotation release.
2) Side panels and door to the electric panel, opened with a special key	5) Oil filling cap (with safety breather)
3) Fixed protection device - cooling fan	6) Safety valve

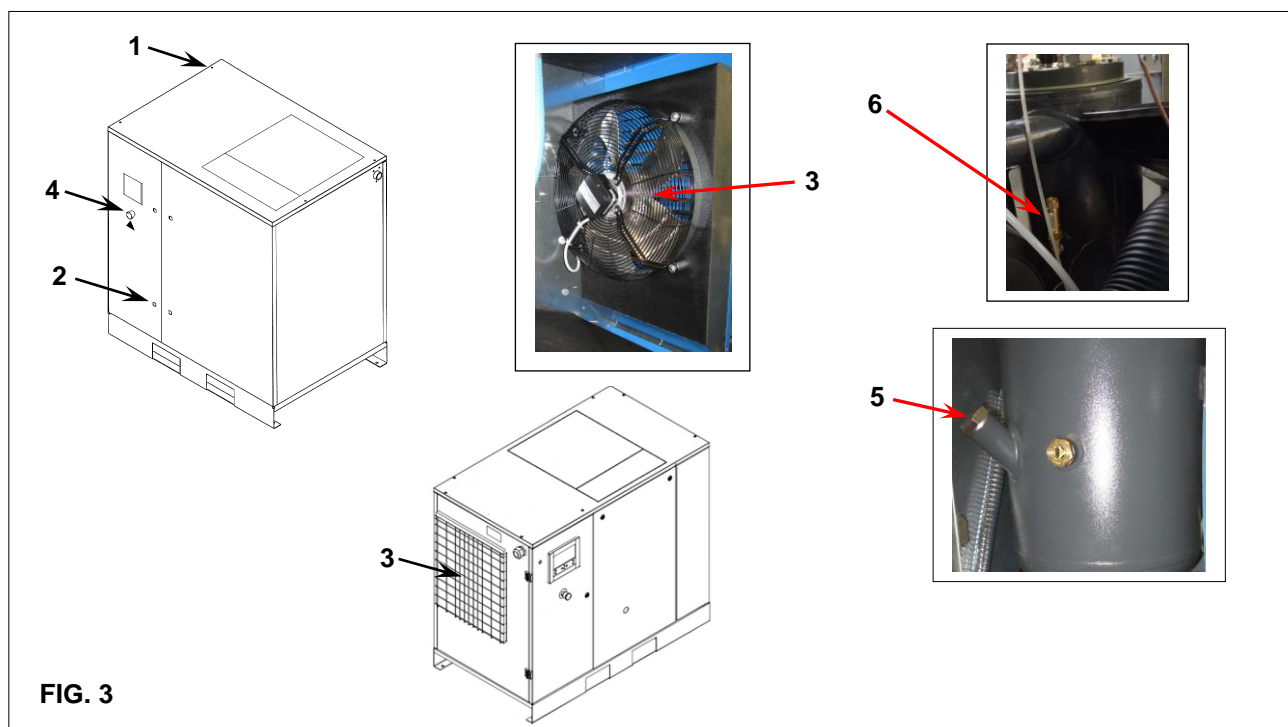

FIG. 3

7.2 SAFETY DEVICES FOR DRYER UNIT

1) Fan protection

2) Earth

FIG. 4

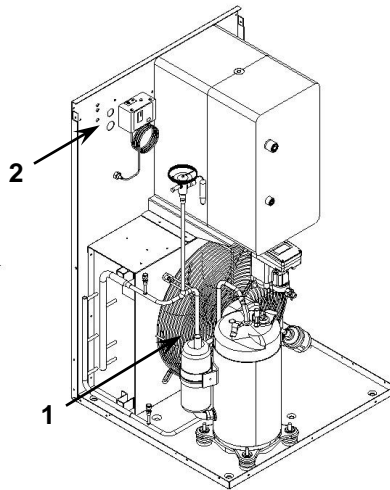

8.0 POSITION OF PLATES

8.1 POSITION OF THE DANGER PLATES FOR COMPRESSOR UNIT

The plates fitted on the compressor unit are part of the machine; they have been applied for safety purposes and must not be removed or spoiled for any reason.

1) Dangers plate Code 1079990348

2) Plate "Machine with automatic start" 2202260791

FIG. 5

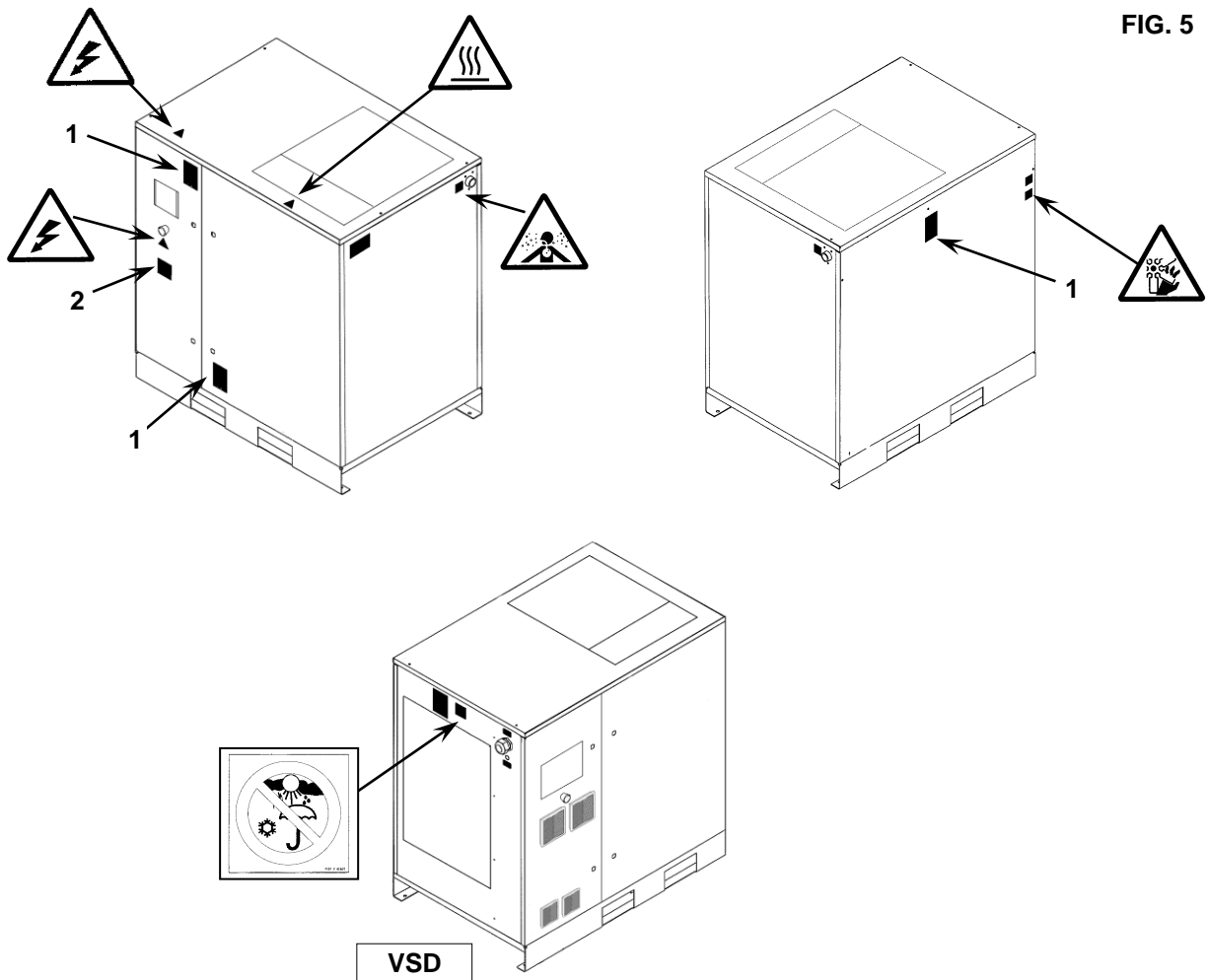

8.2 POSITION OF THE DANGER PLATES FOR DRYER UNIT

The plates fitted on the compressor unit are part of the machine; they have been applied for safety purposes and must not be removed or spoiled for any reason.

1) Dangers plate Cod. 1079990148

FIG. 6

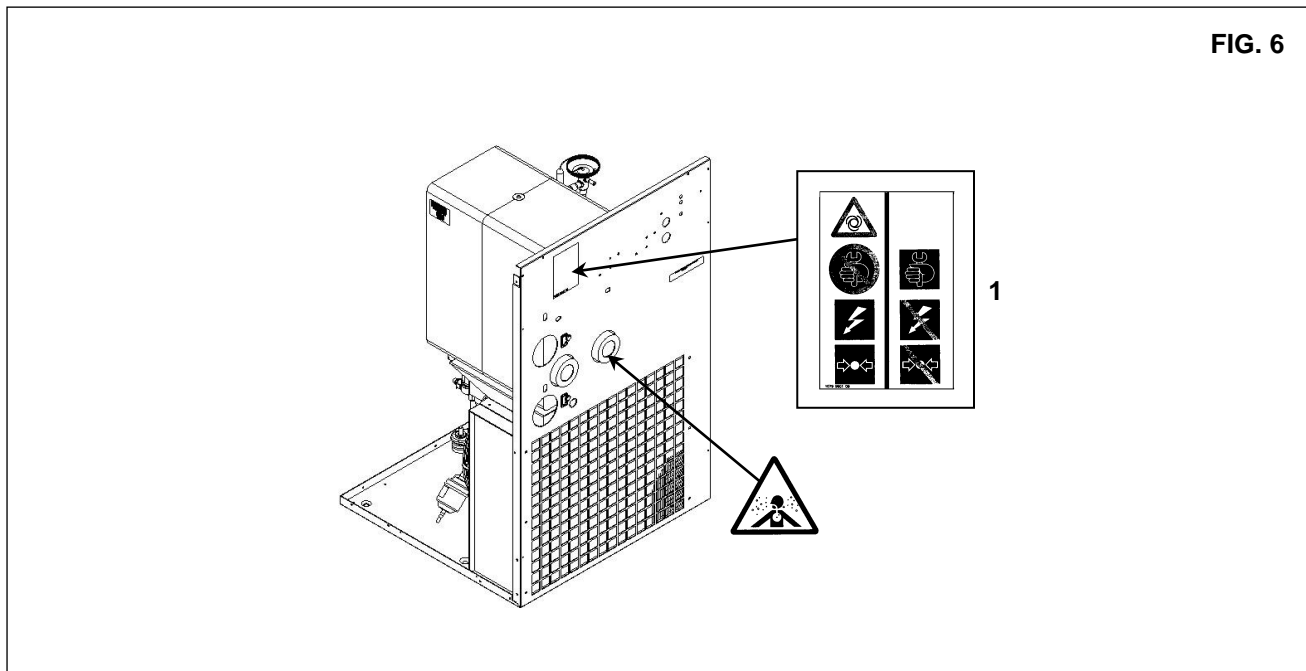

8.3 POSITION OF THE DATA PLATE FOR COMPRESSOR UNIT

1) Identification plate

FIG. 7

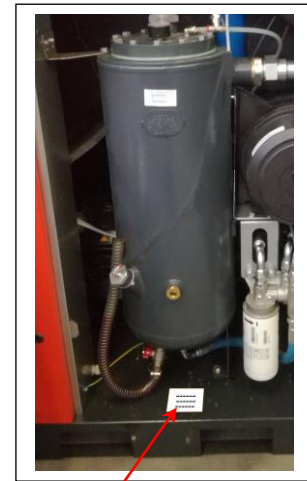
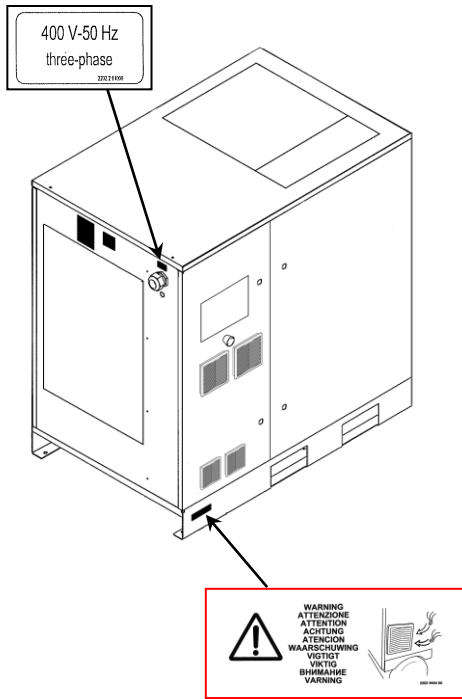

- (en) Drain condensate from the oil collector
- (it) Scaricare la condensa del collettore olio
- (fr) Purger l'eau de condensation du collecteur huile
- (de) Kondenswasser aus dem Ölbehälter ablassen
- (es) Desaguar la condensación del colector de aceite
- (nl) Condensaat aftappen uit de olievangbak
- (da) Dræn kondensat fra oliebeholderen
- (no) Tapp av kondensat fra oljeopsamleren
- (fi) Cuihiti kondensatit öljysäiliöstä
- (sv) Avtappa kondensat från oljetanken
- (el) Ξυπνοθετὸ κόνδενσάτ ζ ἔλαιου ἰνῆρα
- (ru) Тщательно опорожните лубод
- (pt) Aborrecer a vaporização de óleo para o acumulador de óleo
- (pl) Spuścić kondensat ze zbiornika oleju
- (hr) Pužiti sa kondenzacije dio kolektor de oleja
- (ro) Drenați condensul din colectorul de ulei
- (bg) Източете кондензатът и посудите за олиг

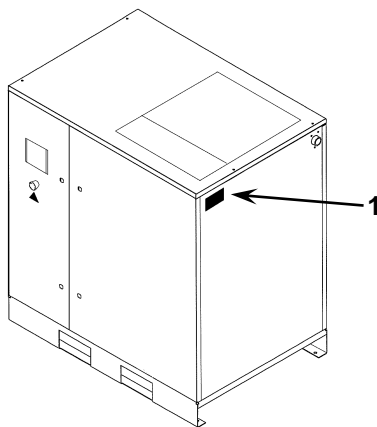

Direction of rotation fixed speed and VSD.

8.4 POSITION OF THE DATA PLATE FOR DRYER

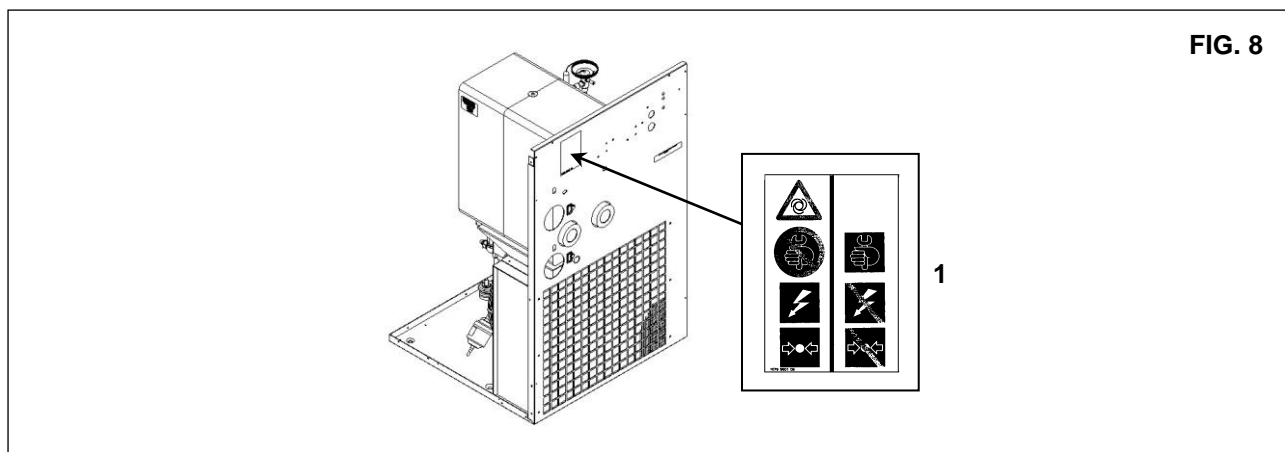

9.0 COMPRESSOR ROOM

9.1 FLOOR

The floor must be even and of industrial type; the total weight of the machine is shown in the Chap. 13.0
Remember the total weight of the machine when positioning it.

9.2 VENTILATION

When the machine is operating, the room temperature must not be higher than **40 °C** or lower than **4 °C**.

The volume of the room must be about **60 m³**. The room must be provided with 2 openings for ventilation with a surface area of about **1,6 m²** each. The first opening must be in a high position to evacuate the hot air, the second opening must be low to allow the intake of external air for ventilation. If the environment is dusty it is advisable to extract fit a filtering panel on this opening.

9.3 EXAMPLES OF VENTILATION OF THE COMPRESSOR ROOM

FIG. 9

ATTENTION: Removable pipe to allow cleaning of the radiator.

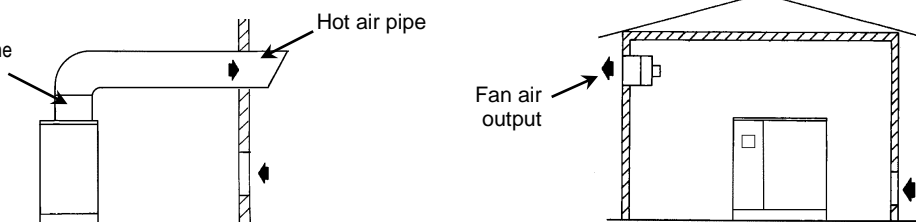

7Please ensure the appropriate composition of the air within the machine room: - clean with no damaging contaminants (e.g., dust, fibers, fine sand) - free of explosive or chemically unstable gases or vapors - free of acid/alkaline forming substances, particularly ammonia, chlorine or hydrogen sulfide.

Similar failures shall affect warranty reimbursements.

10.0 TRANSPORT AND HANDLING

The machine must be transported as shown in the following figures.

FIG. 10

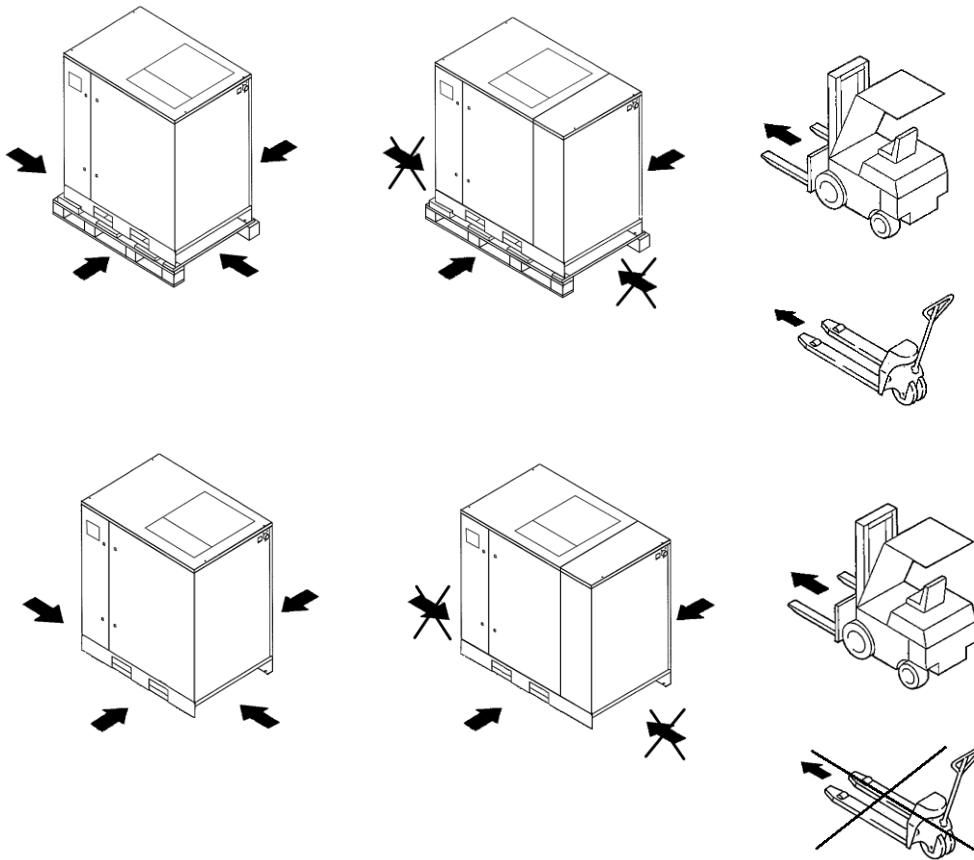

11.0 UNPACKING

After removing the packing, ensure that the machine is unbroken and that there are no visibly damaged parts. If you are in doubt, do not use the machine but contact the manufacturer or to your dealer. The packing material (plastic bags) must not be left within the reach of children or abandoned in the environment, as they are a potential source of danger and pollution. Dispose of these materials in the approved collection centres.

12.0 INSTALLATION**12.1 POSITIONING**

After unpacking the equipment and preparing the compressor room, put the machine into position, checking the following items:

- ensure that there is sufficient space around the machine to allow maintenance (see Fig. 11).

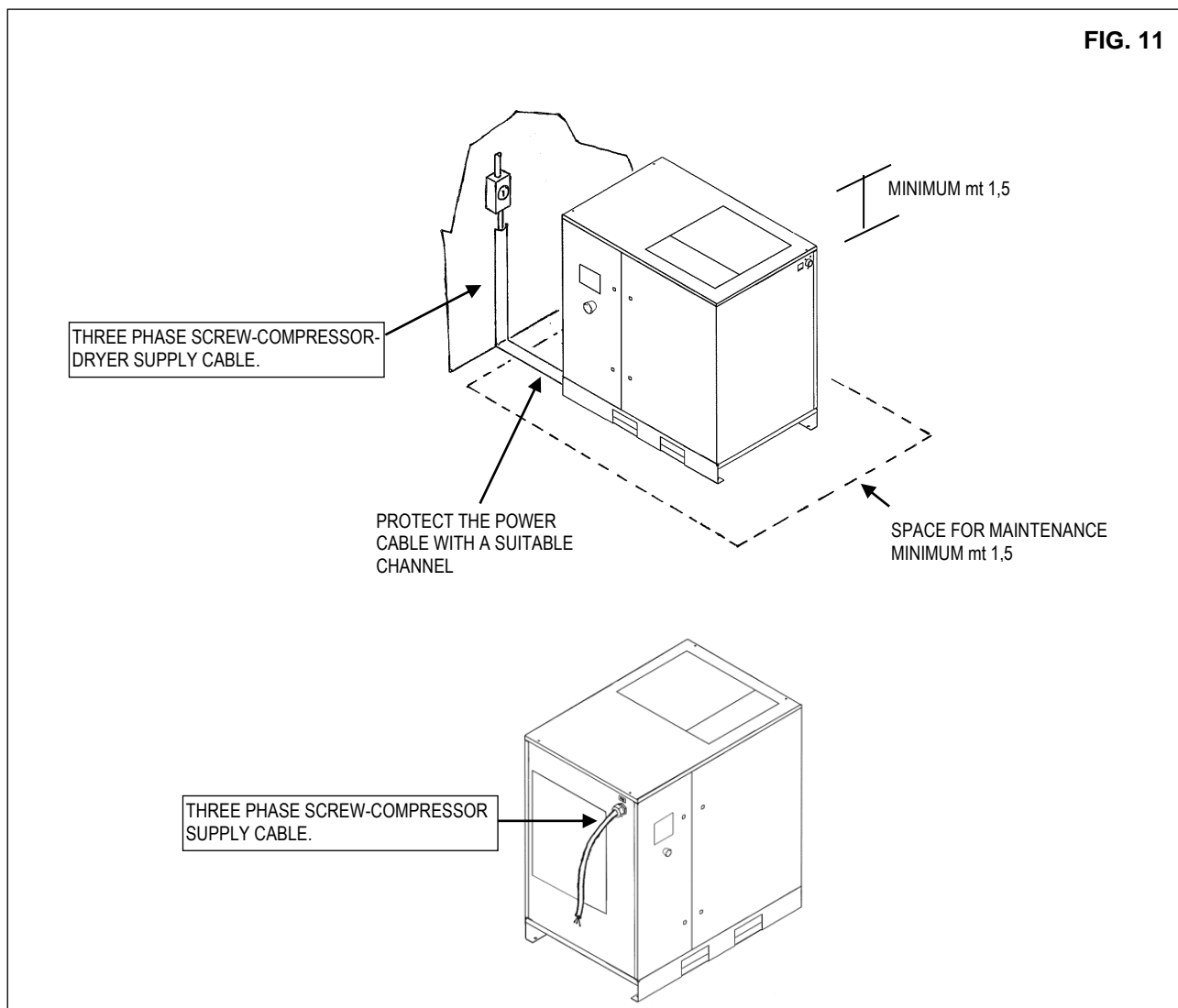

ENSURE THAT THE OPERATOR CAN SEE THE WHOLE MACHINE FROM THE CONTROL PANEL AND CHECK THE PRESENCE OF ANY UNAUTHORIZED PERSONS IN THE VICINITY OF THE MACHINE.

12.2 ELECTRICAL CONNECTION

- Check that the supply voltage is the same as the value indicated on the machine data plate.
- Check the condition of the line cables and ensure that there is an efficient earth lead.
- **Ensure that there are disconnecter switch and fuses upstream the machine for compressor and dryer. For details (size and type) see wiring/service diagram**
- Connect the machine power cables with the greatest care, according to the standards in force. These cables must be as indicated on the machine wiring diagram.
- Connect the cables to the charging clamps on the electric panel and make sure they are properly tightened. After the first 50 working hours, check that the screws on the electric terminals are tight.



ONLY PROFESSIONALLY SKILLED PERSONNEL MAY HAVE ACCESS TO THE ELECTRIC PANEL. SWITCH OFF THE POWER BEFORE OPENING THE DOOR OF THE ELECTRIC PANEL. COMPLIANCE WITH THE REGULATIONS IN FORCE CONCERNING ELECTRIC PLANTS IS FUNDAMENTAL FOR OPERATOR SAFETY AND FOR THE PROTECTION OF THE MACHINE.

CABLES, PLUGS AND ALL OTHER TYPE OF ELECTRIC MATERIAL USED FOR THE CONNECTION MUST BE SUITABLE FOR THE USE AND COMPLYING WITH THE REQUIREMENTS STATED BY THE REGULATIONS IN FORCE.

ENGLISH

12.3 CONNECTION TO THE COMPRESSED AIR NETWORK

Isolation (ball) valve Ref. 1 between the machine and the compressed air network so that the compressor may be isolated during maintenance operations (see figure 12).



PIPES, FITTINGS AND CONNECTIONS USED FOR THE CONNECTION OF THE ELECTROCOMPRESSOR TO THE COMPRESSED AIR NETWORK MUST BE SUITABLE TO THE USE ACCORDING TO THE INSTRUCTIONS OF THE REGULATIONS IN FORCE IN THE COUNTRY OF USE.

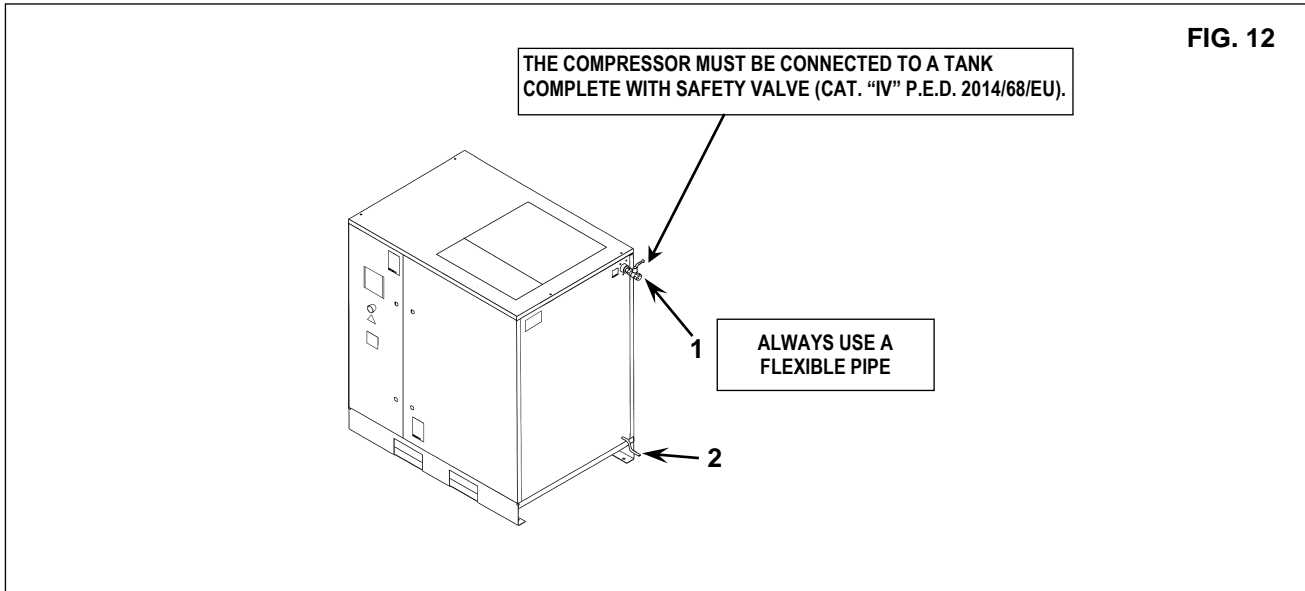

The automatic condensate drain Ref. 2 Fig. 12, are led outside the machine with a flexible pipe that may be inspected. Drainage must comply with the local regulations in force.



THE MANUFACTURER CANNOT ACCEPT LIABILITY, FOR ANY DAMAGE AND OR FAILURE CAUSED BY FAILURE TO COMPLY WITH THESE INSTRUCTIONS.

12.4 STARTING UP

See part B of this manual, **Chapter 20.0**

13.0 DIMENSIONS AND TECHNICAL DATA

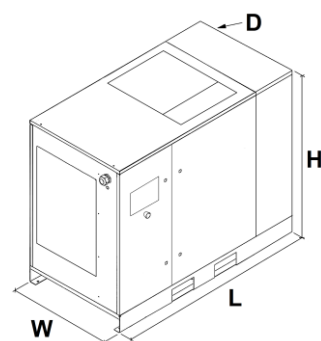
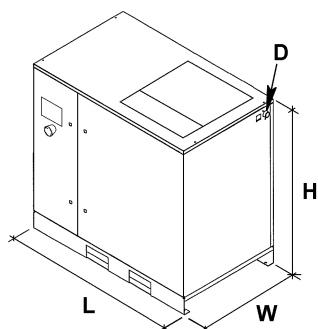

	Dimensions (mm)			Air connection
	L	W	H	D
HP 40 - 50 - 60 kW 30 - 37 - 45	1320	830	1555	1"1/4
Weight Kg.				
HP 40 - kW 30	589		605 (IVR)	
HP 50 - kW 37	610		626 (IVR)	
HP 60 - kW 45	629		656 (IVR)	

	Dimensions (mm)			Air connection
	L	W	H	D
HP 40 - 50 - 60 kW 30 - 37 - 45	1810	830	1555	1"1/4
Weight Kg.				
HP 40 - kW 30	707		723 (IVR)	
HP 50 - kW 37	728		744 (IVR)	
HP 60 - kW 45	747		774 (IVR)	



	HP 40- kW 30				HP 50 - kW 37				HP 60 - kW 45			
	7,5	8,5	10	13	7,5	8,5	10	13	7,5	8,5	10	13
Max. pressure bar	7,5	8,5	10	13	7,5	8,5	10	13	7,5	8,5	10	13
Nominal pressure bar	7	8	9.5	12.5	7	8	9.5	12.5	7	8	9.5	12.5
Standard air capacity m3/h:	319	308	274	241	396	365	342	310	454	436	400	349
Noise product. dB(A)	71,5				73				74,5			
Oil operation setting °C	71				71				71			
Oil load lt.	21				21				22			



	HP 40- kW 30 (VSD)			HP 50 - kW 37 (VSD)			HP 60 - kW 45 (VSD)		
	-	10	13	-	10	13	-	10	13
Max. pressure bar	-	10	13	-	10	13	-	10	13
Nominal pressure bar	7	9.5	12.5	7	9.5	12.5	7	9.5	12.5
Standard air capacity m3/h:	318	274	225	401	343	272	447	404	353
Noise product. dB(A)	71,5			73			74,5		
Oil operation setting °C	71			71			71		
Oil load lt.	21			21			22		

	HP 40- kW 30				HP 50 - kW 37				HP 60 - kW 45			
	107	132	157	182	107	132	157	182	107	132	157	182
Max pressure PSI	107	132	157	182	107	132	157	182	107	132	157	182
Nominal pressure PSI	100	125	150	175	100	125	150	175	100	125	150	175
Standard air capacity m3/h:	317	293	259	236	401	365	324	311	459	439	381	344
Noise product. dB(A)	71,5				73				74,5			
Oil operation setting °C	71				71				71			
Oil load lt.	21				21				22			

	HP 40- kW 30 (VSD)			HP 50 - kW 37 (VSD)			HP 60 - kW 45 (VSD)		
	107	157	182	107	157	182	107	157	182
Max pressure PSI	107	157	182	107	157	182	107	157	182
Nominal pressure PSI	100	150	175	100	150	175	100	150	175
Standard air capacity m3/h:	318	271	271	401	338	338	447	404	404
Noise product. dB(A)	71,5			73			74,5		
Oil operation setting °C	71			71			71		
Oil load lt.	21			21			22		

ENGLISH

Type Dryer	Freon R 410A Kg.		 Nominal Power W		 Nominal Power W		Nominal Power W		bar MAX. 
	50 Hz	60 Hz	50 Hz	60 Hz	50 Hz	60 Hz	50 Hz	60 Hz	
BE10S	See data plate dryer		1665	1810	135	190	1800	2000	14

Type Dryer	Freon R 134a Kg.		 Nominal Power W		 Nominal Power W		Nominal Power W		bar MAX. 
	50 Hz	60 Hz	50 Hz	60 Hz	50 Hz	60 Hz	50 Hz	60 Hz	
BE10S (CSA)	See data plate dryer		1860		220		2080		14

Reference conditions:

Ambient temperature 25 °C
 Inlet air temperature 35 °C
 Pressure 7 bar
 Dew point in pressure 3 °C

Limit conditions:

Max. ambient temperature 40°C
 Min. ambient temperature 4°C
 Max. working pressure 14 bar

14.0 MACHINE ILLUSTRATION

14.1 GENERAL LAY-OUT FOR DRYER

- | | |
|--|---|
| 1 Air suction filter | 13 Pressure gauge tank |
| 2 Thermostatic valve | 14 Controller |
| 3 Oil filter | 15 Safety valve (*) |
| 4 Air-oil cooler | 16 Fan motor |
| 6 Minimum pressure valve | 17 Electric motor |
| 7 Air-oil separator with oil separating filter | 18 Screw compressor |
| 8 Top-up or oil filling cap | 19 Suction unit |
| 9 Emergency stop push button | 20 Water separators and drains (WSD) (Option) |
| 10 Oil gauge | |
| 11 Oil discharge | |
| 12 Oil tank | |
- * IT IS FORBIDDEN TO TAMPERE WITH THE PRESSURE SETTING OF THE SAFETY VALVE**

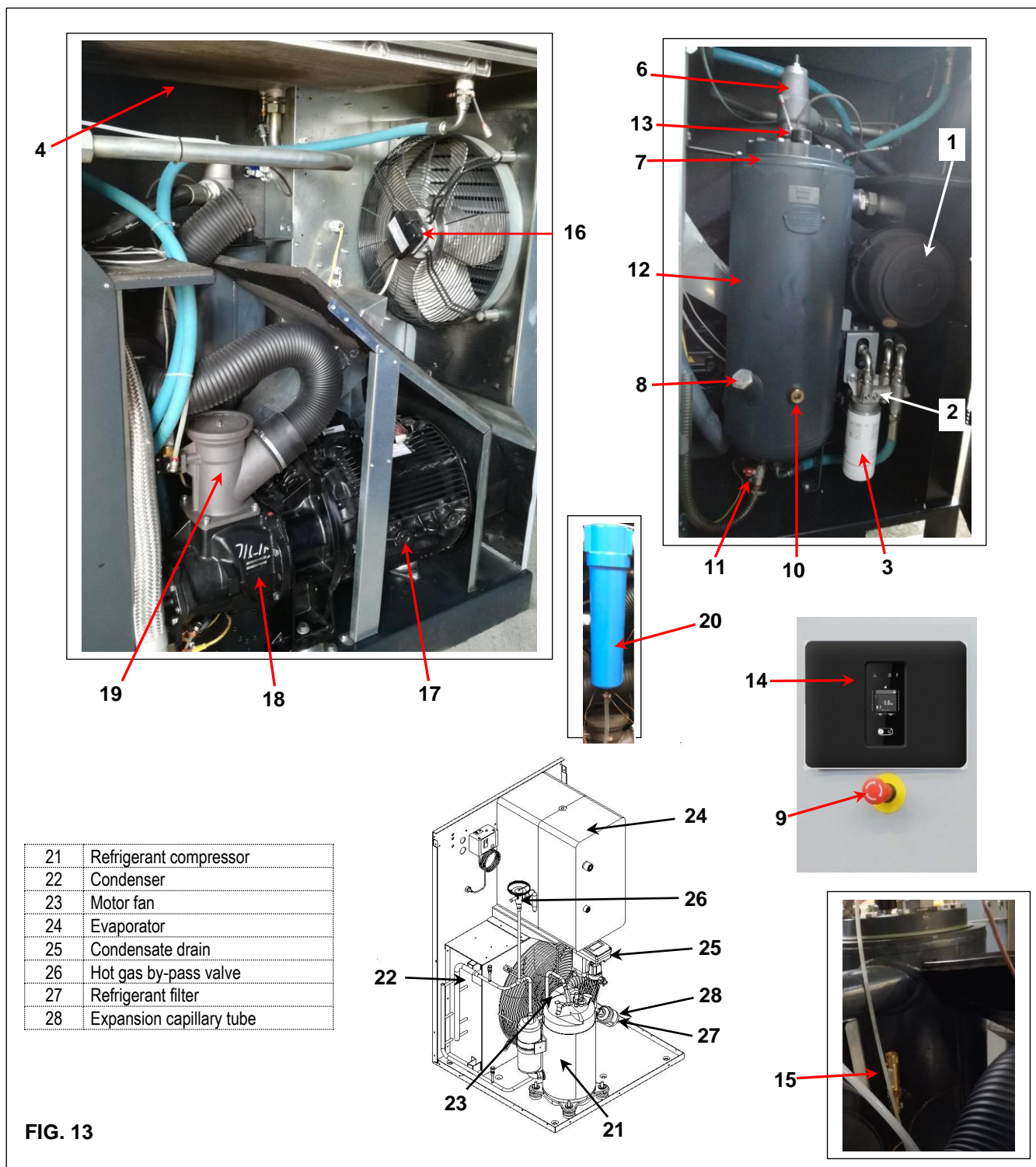

21	Refrigerant compressor
22	Condenser
23	Motor fan
24	Evaporator
25	Condensate drain
26	Hot gas by-pass valve
27	Refrigerant filter
28	Expansion capillary tube

FIG. 13



BEFORE CARRYING OUT THE OPERATION TEST, READ CAREFULLY AND ACQUIRE A GOOD KNOWLEDGE OF THE COMMAND FUNCTIONS.

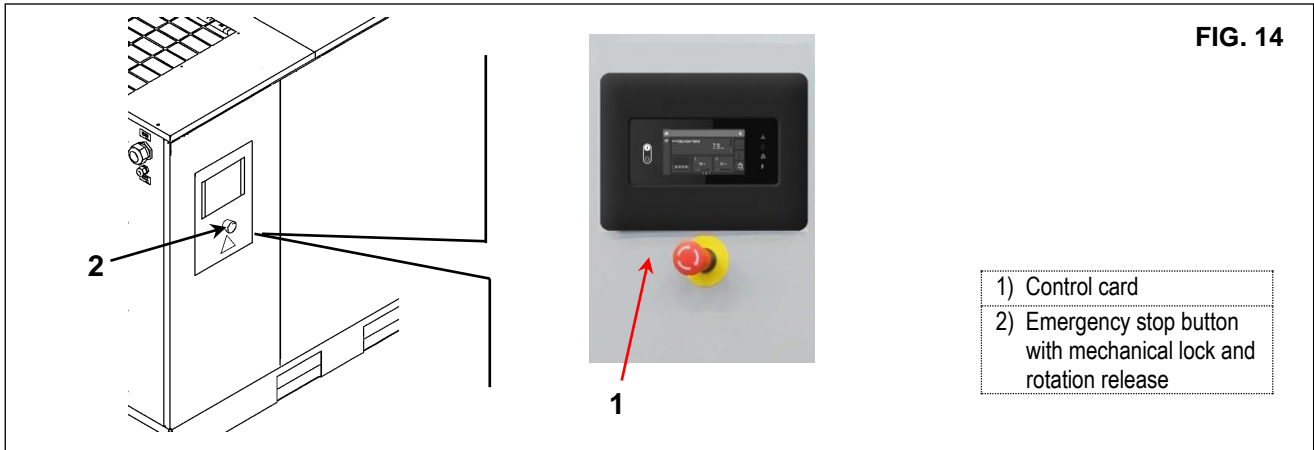

14.3 SWIPE CONTROLLER (Default controller for Fix Speed units)

Controller



85384D

The Elektronikon™ Swipe controller

Introduction

The controller has following functions:

- Controlling the unit
- Protecting the unit
- Monitoring components subject to service
- Automatic restart after voltage failure (ARAVF)

Automatic control of the unit

The controller maintains the net pressure between programmable limits by automatically loading and unloading the unit.

A number of programmable settings, e.g. the unloading and loading pressures, the minimum stop time and the maximum number of motor starts are taken into account.

The controller stops the unit whenever possible to reduce the power consumption and restarts it automatically when the net pressure decreases. If the expected unloading period is too short, the unit is kept running to prevent too short standstill periods.

Protecting the unit Shutdown

If the element outlet temperature exceeds the programmed shutdown level, the unit will be stopped.

The unit will also be stopped in case of overload of the drive motor or fan motor.



Before remedying, consult the [Safety precautions](#).
Before resetting a warning or shutdown message, always solve the problem. Frequently resetting these messages without remedying may damage the unit.

Shutdown warning

A shutdown warning level is a programmable level below the shutdown level.

If one of the measurements exceeds the programmed shutdown warning level, a message will appear on the display and the general alarm LED will light up to warn the operator before the shutdown level is reached.

The message disappears as soon as the warning condition disappears or after a manual warning reset on the display.

A warning will also appear if the dew point temperature is too high in relation to the oil temperature (on units with integrated dryer).

When the shutdown warning is shown, press stop button to stop the unit and wait until the unit has stopped. Switch off the voltage, inspect the unit and remedy if necessary. The warning message will disappear as soon as the warning condition disappears.

Service warning

The service timer has a programmed time interval. If the service timer exceeds the programmed value, this will be indicated on the display to warn the operator to carry out the service actions.

When the service warning is shown, stop the unit, switch off the voltage and carry out the required service actions. See section Preventive Maintenance.

Automatic restart after voltage failure (ARAVF)

The controller has a built-in function to automatically restart the unit when the voltage is restored after voltage failure. For units leaving the factory, this function is made inactive.

To activate this function, you have to change the Access level to 'Service user'. This profile is password protected. See Controller settings menu.

Consult your supplier.



If the function is activated and provided the controller was in the automatic operation mode, the unit will automatically restart if the supply voltage to the module is restored.
The ARAVF label (see section Pictographs) shall be glued near to the controller.

Control panel

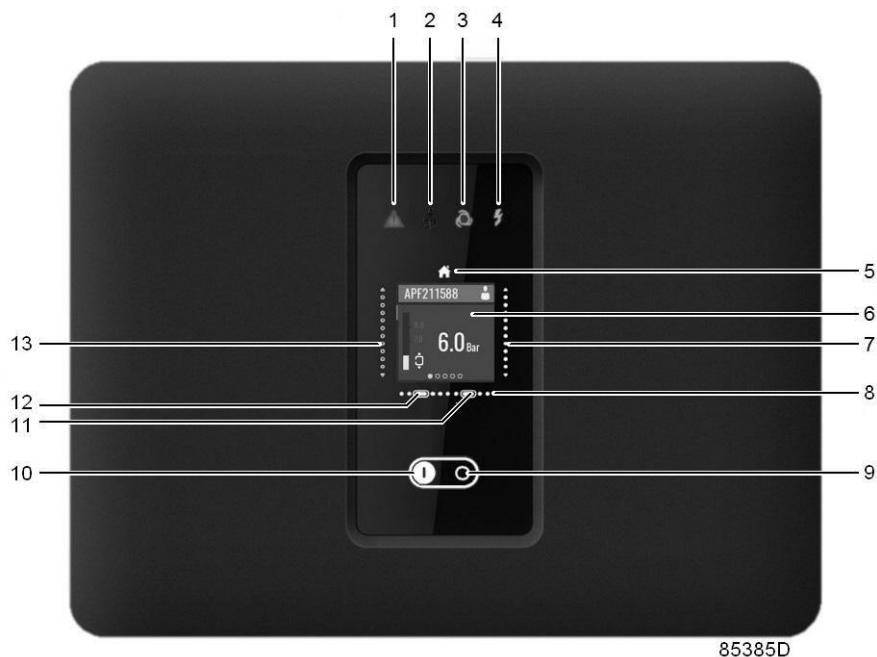







Control panel

Parts and functions

Reference	Designation	Function
1	Warning sign	Flashes in case of a shut-down, is lit in case of a warning condition.
2	Service sign	Is lit when service is needed.
3	Operation sign	Is lit when the unit is running.
4	Voltage sign	Indicates that the voltage is switched on.
5	Home button	Tap this button to return to the Main screen.
6	Display	The information is shown on the display.
7	Right vertical swipe bar	Swipe up or down to modify a setting. After modifying, tap the cancel (12) or confirm (11) button.
8	Horizontal swipe bar	Swipe left or right to move horizontally through the menu.
9	Stop button	Tap this button to stop the unit.
10	Start button	Tap this button to start the unit. The operation sign (3) lights up. The controller is operative.
11	Confirm button	After modifying a value, tap the confirm button to finalize.
12	Cancel button	Tap the cancel button to cancel a modification.
13	Left vertical swipe bar	Swipe up or down to move vertically through the menu.

Icons used



Menu icons

Menu	Icon
Main screen	 85385D
Machine Settings	 85237D
Aux. Equipment Parameters	 85243D
Data	 85233D
Service	 85234D
Controller Settings	 85238D
Information	 85250D







Status icons

Icon	Description
 85262D	Motor Stopped
 85263D	Motor Stopped Wait
 85264D	Running Unloaded
 85265D	Manual Unload
 85266D	Running Unloaded Wait
 85267D	Running Loaded
 85269D	Running Loaded Wait
 85271D	Machine Control Mode, Local
 85272D	Machine Control Mode, Remote

ENGLISH

 85273D	Machine Control Mode, LAN
 85274D	Auto Restart After Voltage Failure (ARAVF)

System icons

Icon	Description
 85276D	Basic User
 85277D	Advanced User
 85278D	Service User
 85283D	Change between screens (indication)
 85290D	Reset
	This chapter gives a general survey of available icons. Not all icons mentioned in this chapter are applicable to every machine.

Menu

Procedure

Starting from the main screen, use the left vertical swipe bar to navigate through the menu items.

Use the horizontal swipe bar to navigate through the different screens of a menu item. The page indicator



shows how many screens there are available for the current menu item, depending on the user access level.

Menu structure

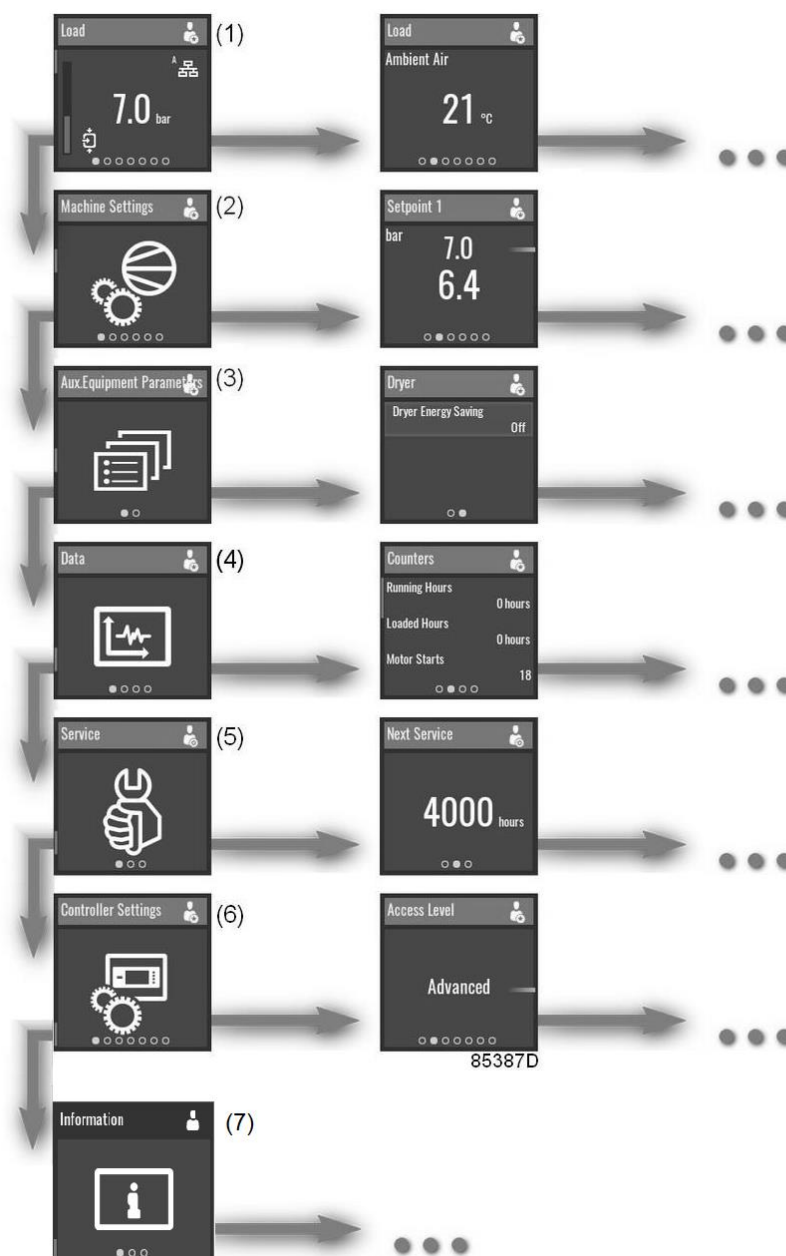

Reference	Designation	Function
(1)	Main screen	Next to the main screen, a maximum of 3 extra values can be shown.
(2)	Machine settings	Setpoints, Regulation settings and Control parameters can be viewed and modified through this menu.
(3)	Aux. Equipment parameters	Settings for auxiliary equipment can be viewed and modified through this menu. This menu is only visible when the Access level is set to Advanced. See Controller settings.
(4)	Data	The data menu contains information about the Counters, Inputs and Outputs.
(5)	Service	Information about the service interval can be found through this menu. This menu is only visible when the Access level is set to Service. See Controller settings.

ENGLISH

(6)	Controller settings	Different controller settings, such as Access level or Ethernet settings can be viewed and modified through this menu.
(7)	Informations	Here are listed MAC address and software information loaded

This is the main menu structure. The structure can be different depending on the configuration of the unit.

Select or modify a setting

Several settings can be modified. The process of selecting or modifying a setting anywhere in the menu is basically the same.

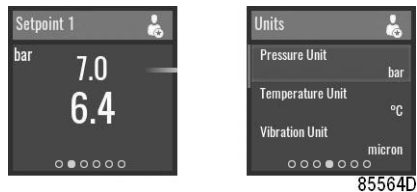

Examples of modifiable settings

Select

In these examples, the upper value is selected.

To select the lower value, swipe down on the left vertical swipe bar. **Modify**

To modify the selected value, tap the right vertical swipe bar.



Swipe up or down on the right vertical swipe bar to change the value.

On the horizontal swipe bar, tap 'V' to confirm or 'X' to decline.

Main screen

Function

The Main screen is the screen that is shown automatically when the voltage is switched on. It is switched off automatically after a few minutes when there is no touch input.

Swipe left to navigate to the following screens:

- Element outlet temperature
- Dryer pressure dew-point (in case of integrated dryer only)
- Running hours (Loaded hours for compressors without integrated dryer)
- Setpoint used
- Manual unload (optional)
- Status

Description

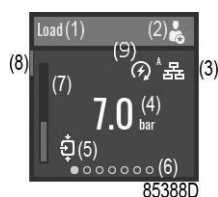

Reference	Designation	Function
(1)	Screen information	On the main screen, the screen information bar shows the current status of the machine. When scrolling through menus, the name of the current menu item is shown.
(2)	Access level icon	The access level icon shows the current access level setting. See Controller settings menu to switch between User, Advanced or Service.
(3)	Control mode icon	The control mode icon shows the current control mode setting. <ul style="list-style-type: none"> Local control via start/stop buttons Remote control via digital input(s) LAN control via the network. When in Remote or LAN control, the start/ stop buttons on the controller will not work.
(4)	Input value	This field contains an input value, depending on the type of the machine. In this case, the current outlet pressure is shown.
(5)	Status	This icon shows the current status of the unit.
(6)	Page indicator (Breadcrumbs)	Indicates how many pages there are available for a given menu item. The page which is currently active is indicated by a filled white circle. Swipe left or right to go to another screen.
(7)	Value bar	This is an indicator for the input value, also shown on the main screen. When the regulation sensor is selected 2 extra load, unload lines are shown.
(8)	Scrollbar	This is an indication of the vertical position in the menu. Swipe up or down to go to another menu item.
(9)	ARAVF icon	The ARAVF icon is shown when the Automatic Restart functionality is activated.

Parameters

Starting from the main screen, swipe left to scroll through predefined IO or counter data. (optional)



ENGLISH

Setpoint used

Starting from the main screen, swipe left until the Setpoint used screen is shown.



To switch to a different setpoint, swipe up or down on the left vertical swipe bar or tap next to the corresponding square.

Manual unload

Starting from the main screen, swipe left until the Manual unload screen is shown.



Manual unload can only be activated when the machine is in LOAD and Local control.

To manually unload the unit, tap on the left vertical swipe bar.

Status

Starting from the main screen, swipe left until the Status screen is shown.



This screen shows the current status of the unit.

If an alarm is active, tap the right vertical swipe bar.



To reset the alarm, press the confirm button under the reset icon.

To cancel without resetting, press the cancel button under the red 'X' icon.



Before remedying, consult the Safety precautions.
Before resetting a warning or shutdown message, always solve the problem. Frequently resetting these messages without remedying may damage the unit.

Shutdown

Description

The unit will be shut down in following circumstances:

- In case the temperature at the outlet of the element exceeds the programmed shut down level (detected by temperature sensor (TT11)).
- In case of too high oil or air/oil temperature (detected by temperature switch TSHH11 or TSHH12).
- In case of overload of the motor (M1) or the fan motor (M2).
- In case of error of the outlet pressure sensor (PT20).
- In case of incorrect phase sequence, detected by phase sequence relay (K25).

Element outlet temperature (TT11)

If the element outlet temperature, measured by temperature sensor TT11, exceeds the shutdown level (see section Programmable settings), the unit will be shutdown, alarm LED (1) will flash, automatic operation LED (3) will go out and the following screen will appear:

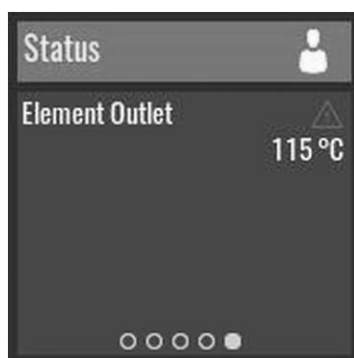

85692D

Main screen with shutdown indication, element outlet temperature

Swipe left (8) until the actual element outlet temperature appears.



85693D

Shutdown screen, element outlet temperature

The above screen shows that the temperature at the outlet of the element is 117 °C. Actions:

- Switch off the voltage and remedy the problem cause.
- After remedying and when the shutdown condition has disappeared, switch on the voltage and restart the unit.

Other shutdown causes

In case the unit is shut down (or cannot start) by one of following causes:

- Too high element outlet temperature, detected by temperature switch (TSHH11) or additional temperature switch (TSHH12).
- Overload of the motor (M1) or the fan motor (M2).
- Incorrect phase sequence, detected by phase sequence relay (K25).

The unit will be shutdown, alarm LED (1) will flash, automatic operation LED (3) will go out and following screen will appear:

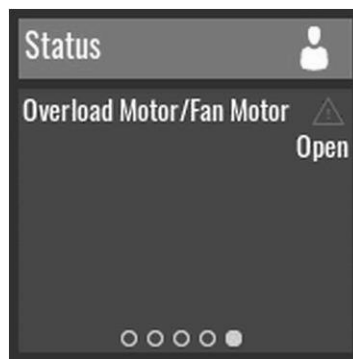

85694D

Shutdown screen, overload

Actions:

- Switch off the voltage and remedy the problem cause.
- In case of incorrect phase sequence, reverse two phases of the supply cable.
- If the additional temperature switch (TSHH12) has tripped, you must contact the customer center.
- After remedying and when the shutdown condition has disappeared, switch on the voltage and restart the unit.
The shutdown message will disappear automatically when the shutdown condition has disappeared.

Machine settings menu**Function**

The Machine Settings menu provides the ability to view and modify several machine settings.

Swipe left to navigate to the following screens:

- Setpoint 1 (optional)
- Setpoint 2 (optional)
- Regulation
- Control Mode
- Auto Restart

Procedure

To view the Machine Settings menu:

1. Tap the Home button



on top of the screen to go to the main screen.

2. Swipe up on the left vertical swipe bar until the Machine Settings menu is shown:



To have the access to all parameters Advance access level is required (See Controller Setting menu)

Setpoint 1

Starting from the Machine Settings menu, swipe left until the Setpoint 1 screen is shown.



To select a load and unload setpoint, or to modify the values, see section Select or modify a setting.



Setpoint 2

Starting from the Machine Settings menu, swipe left until the Setpoint 2 screen is shown.



To select a load and unload setpoint, or to modify the values, see section Select or modify a setting.

Regulation

Starting from the Machine Settings menu, swipe left until the Regulation screen is shown.



To select a menu item, or to change the setting, see section Select or modify a setting.

ENGLISH

Control Mode

Starting from the Machine Settings menu, swipe left until the Control Mode screen is shown.



Following control modes are available:

- Local control through start/stop buttons
- Remote control through digital input(s)
- LAN control through UDP ethernet commands.

When in Remote or LAN control, the start/stop buttons on the controller will not work.

To change the setting, see section Select or modify a setting.

Auto Restart

Starting from the Machine Settings menu, swipe left until the Auto Restart screen is shown.

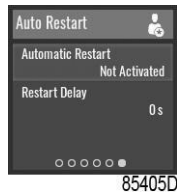

The controller has a built-in function to automatically restart the compressor when voltage is restored after voltage failure. This function is deactivated in compressors leaving the factory and can only be modified after entering a password, please consult your supplier to activate this function.

To select a menu item, or to change the setting, see section Select or modify a setting.

Auxiliary equipment parameters menu

Function

The Aux. Equipment parameters menu provides the ability to view and modify several settings related to the auxiliary equipment of the unit.

Swipe left to navigate to the following screens:

- Dryer (optional)
- Fan (optional)
- Internal or External Icons

Procedure

To view the Aux. Equipment parameters menu:

1. Tap the Home button



on top of the screen to go to the main screen.

2. Swipe up on the left vertical swipe bar until the Aux. Equipment parameters menu is shown:



To have the access to all parameters Advance access level is required (See Controller Setting menu)

Dryer

Starting from the Aux. Equipment parameters menu, swipe left until the Dryer screen is shown.



SmartBox

Starting from the Aux. Equipment parameters menu, swipe left until the Internal SmartBox screen is shown.

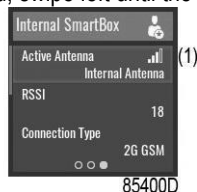

(1)	The reception quality of the internal antenna can be monitored.
-----	---



To select a menu item, or to change the setting, see section [Select or modify a setting](#).

Data menu

Function

The Data menu provides the ability to view several important values.

Swipe left to navigate to the following screens:

- Counters
- Inputs
- Outputs

Procedure

To view the Data menu:

1. Tap the Home button



on top of the screen to go to the main screen.

2. Swipe up on the left vertical swipe bar until the Data menu is shown:



Counters

Starting from the Data menu, swipe left until the Counters screen is shown.

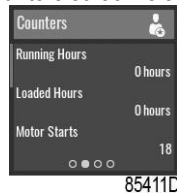

Select

To select a different item, swipe up or down on the left vertical swipe bar.

Inputs (Advanced access level is required. See below on Controller settings menu section)

Starting from the Data menu, swipe left until the Inputs screen is shown.

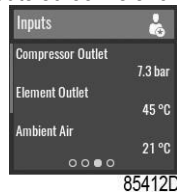

Select

To select a different item, swipe up or down on the left vertical swipe bar.

Outputs (Advanced access level is required. See below on Controller settings menu section)

Starting from the Data menu, swipe left until the Outputs screen is shown.

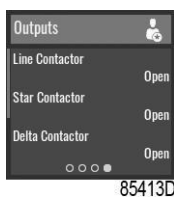

Select

To select a different item, swipe up or down on the left vertical swipe bar.

	<p>Voltage-free outputs may only be used to control or monitor functional systems. They should NOT be used to control, switch or interrupt safety related circuits. Check the maximum allowed load on the label.</p>
	<p>Stop the unit and switch off the supply before connecting external equipment. Check the Safety precautions.</p>

Service menu

Function

The Service menu provides the ability to reset the service timer. This menu is only available as Service user.

Swipe left to navigate to the following screens:

- Next service
- Safety valve test

Procedure

To view the Service menu:

1. Use the controller as a Service user



See Controller settings menu to change the user profile.

2. Tap the Home button



on top of the screen to go to the main screen.

3. Swipe up on the left vertical swipe bar until the Machine Settings menu is shown:

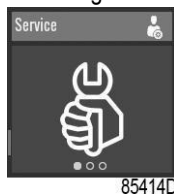

Next Service

Starting from the Service menu, swipe left until the Next Service screen is shown.

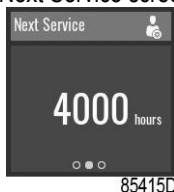

The Next Service will be triggered after the Running Hours value exceeds the Next Service value.

Reset

Tap the right vertical swipe bar, the following screen is now shown:

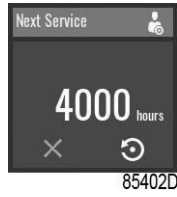

To cancel without resetting, press the cancel button under the red 'X' icon.

To reset the alarm, press the confirm button under the reset icon. The following screen is now shown:

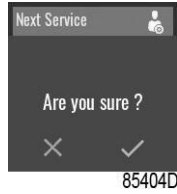

On the horizontal swipe bar, tap 'V' to confirm or 'X' to decline.

Controller settings menu

Function

The Controller Settings menu provides the ability to view and modify several settings of the controller.

Swipe left to navigate to the following screens:

- Access Level
- Language
- Units
- CAN Settings
- Ethernet Settings
- Display Timeout

Procedure

To view the Controller Settings menu:

1. Tap the Home button



on top of the screen to go to the main screen.

2. Swipe up on the left vertical swipe bar until the Controller Settings menu is shown:

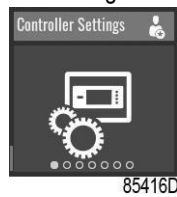

Access Level

Starting from the Controller Settings menu, swipe left until the Access Level screen is shown.

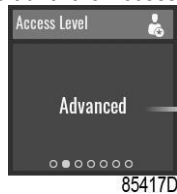

To modify the setting, see section [Select or modify a setting.](#)

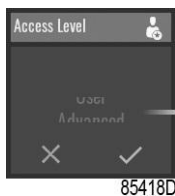

Enter a password

The Service user profile is protected by a password. After selecting the Service user profile, the following screen pops up:



The user can enter the password by swiping up or down on the right vertical swipe bar to select the first digit.

Tap '→' to be able to enter the second digit.

Once the 4 digits are entered, the user can confirm by tapping 'V' or decline by tapping 'X'.

Language

Starting from the Controller Settings menu, swipe left until the Language screen is shown.



To modify the setting, see section Select or modify a setting.

	<p>The controller will reboot after changing this setting.</p>
---	--

Units

The units displayed can be modified through this menu.

CAN Settings

The list of CAN Settings is shown. When CAN is turned off, the settings can be modified.

Ethernet Settings

The list of Ethernet Settings is shown. When ethernet is turned off, IP address, Subnet mask and Gateway can be modified.

	<p>Do not forget to turn on ethernet settings after changing these settings. Otherwise the controller can't connect anymore!</p>
---	--

Display Timeout

Starting from the Controller Settings menu, swipe left until the Display Timeout screen is shown.

Display timeout is used to save energy and save the lifetime of the display. Timer starts after last operator actions on the push buttons or swipe bars.



To modify the setting, see section Select or modify a setting.

Information menu

Function

The Information menu provides the ability to view important information.

Swipe left to navigate to the following screens:

- Help
- Information

Procedure

To view the Information menu:

1. Tap the Home button



on top of the screen to go to the main screen.

2. Swipe up on the left vertical swipe bar until the Information menu is shown:

Help

Starting from the Information menu, swipe left until the Help screen is shown.

The manufacturer's website is shown.

Info

Starting from the Information menu, swipe left until the Info screen is shown.

Following items are displayed:

- Mac Address
- Application Description
- Application Software: nr + version
- Operation: nr + version
- BOOT Software: nr

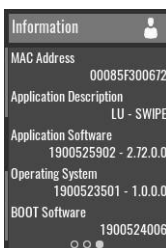

Parameters

		Minimum setting	Factory setting	Maximum setting
Motor running time in star	sec	6	10	15
Load delay time (star-delta)	sec	0	2	10
Number of motor starts	starts/day	0	240	360
Minimum stop time	sec	10	20	30
Restart (ARAVF)	sec	60	60	1200

Protections

		Minimum setting	Factory setting	Maximum setting
Compressor element outlet temperature (shutdown warning level)	°C	50	110	114
Compressor element outlet temperature (shutdown warning level)	°F	122	230	237
Compressor element outlet temperature (shutdown level)	°C	110	115	115
Compressor element outlet temperature (shutdown level)	°F	230	239	239

Service plan

The built-in service timer will give a Service warning message after a pre-programmed time interval has elapsed.

Also see section Preventive maintenance schedule.

Consult customer center if a timer setting has to be changed. See section Calling up/modifying service timer settings.

The intervals must not exceed the nominal intervals and must coincide logically.

Terminology

Term	Explanation
ARAVF	Automatic restart after voltage failure. See section Elektronikon regulator and Activating automatic restart .
Restart delay	This parameter allows to program that not all compressors are restarted at the same time after a power failure (ARAVF active).
Compressor element outlet	The regulator does not accept inconsistent settings, e.g. if the warning level is programmed at 95 °C (203 °F), the minimum limit for the shutdown level changes to 96 °C (204 °F). The recommended difference between the warning level and shutdown level is 10 °C (18 °F).
Delay at shutdown signal	Is the time for which the signal must exist before the compressor is shutdown. If it is required to program this setting to another value, consult customer center.
Minimum stop time	Once the compressor has automatically stopped, it will remain stopped for the minimum stop time, whatever happens with the net air pressure. Consult customer center if a setting lower than 20 seconds is required.
Unloading/ Loading pressure	The regulator does not accept illogical settings, e.g. if the unloading pressure is programmed at 7.0 bar(e) (101 psi(g)), the maximum limit for the loading pressure changes to 6.9 bar(e) (100 psi(g)). The recommended minimum pressure difference between loading and unloading is 0.6 bar (9 psi(g)).

**14.4 SWIPE+ CONTROLLER (Default controller for VSD units)
Controller**



85384D

The Elektronikon™ Swipe controller

Introduction

The controller has following functions:

- Controlling the unit
- Protecting the unit
- Monitoring components subject to service
- Automatic restart after voltage failure (ARAVF)

Automatic control of the unit

The controller maintains the net pressure between programmable limits by automatically motor speed regulation, loading and unloading the unit.

A number of programmable settings, e.g. the unloading and loading pressures, the minimum stop time and the unload to stop time are taken into account.

The controller stops the unit whenever possible to reduce the power consumption and restarts it automatically when the net pressure decreases. If the expected unloading period is too short, the unit is kept running to prevent too short standstill periods.

Protecting the unit Shutdown

If the element outlet temperature exceeds the programmed shutdown level, the unit will be stopped.

The unit will also be stopped in case of overload of fan motor, converter alarm or high oil or air/oil temperature detected by temperature switches (TSHH11-12)

	<p>Before remedying, consult the Safety precautions. Before resetting a warning or shutdown message, always solve the problem. Frequently resetting these messages without remedying may damage the unit.</p>
--	---

Shutdown warning

A shutdown warning level is a programmable level below the shutdown level.

If one of the measurements exceeds the programmed shutdown warning level, a message will appear on the display and the general alarm LED will light up to warn the operator before the shutdown level is reached.

The message disappears as soon as the warning condition disappears or after a manual warning reset on the display.

A warning will also appear if the dew point temperature is too high in relation to the oil temperature (on units with integrated dryer).

When the shutdown warning is shown, press stop button to stop the unit and wait until the unit has stopped. Switch off the voltage, inspect the unit and remedy if necessary. The warning message will disappear as soon as the warning condition disappears.

Service warning

The service timer has a programmed time interval. If the service timer exceeds the programmed value, this will be indicated on the display to warn the operator to carry out the service actions.

When the service warning is shown, stop the unit, switch off the voltage and carry out the required service actions. See section Preventive Maintenance.

Automatic restart after voltage failure (ARAVF)

The controller has a built-in function to automatically restart the unit when the voltage is restored after voltage failure. For units leaving the factory, this function is made inactive.

To activate this function, you have to change the Access level to 'Service user'. This profile is password protected. See Controller settings menu.

Consult your supplier.

	<p>If the function is activated and provided the controller was in the automatic operation mode, the unit will automatically restart if the supply voltage to the module is restored. The ARAVF label (see section Pictographs) shall be glued near to the controller.</p>
---	--

Control panel

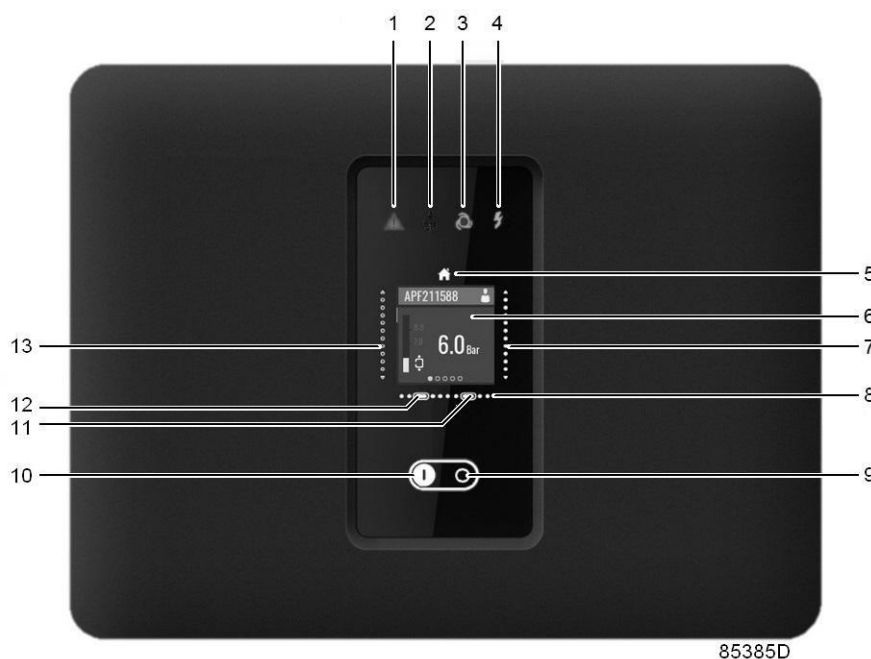

Control panel

Parts and functions







Reference	Designation	Function
1	Warning sign	Flashes in case of a shut-down, is lit in case of a warning condition.
2	Service sign	Is lit when service is needed.
3	Operation sign	Is lit when the unit is running.
4	Voltage sign	Indicates that the voltage is switched on.
5	Home button	Tap this button to return to the Main screen.

ENGLISH

6	Display	The information is shown on the display.
7	Right vertical swipe bar	Swipe up or down to modify a setting. After modifying, tap the cancel (12) or confirm (11) button.
8	Horizontal swipe bar	Swipe left or right to move horizontally through the menu.
9	Stop button	Tap this button to stop the unit.
10	Start button	Tap this button to start the unit. The operation sign (3) lights up. The controller is operative.
11	Confirm button	After modifying a value, tap the confirm button to finalize.
12	Cancel button	Tap the cancel button to cancel a modification.
13	Left vertical swipe bar	Swipe up or down to move vertically through the menu.











Icons used

Menu icons







Menu	Icon
Main screen	 85386D
Machine Settings	 85237D
Aux. Equipment Parameters	 85243D
Data	 85233D
Service	 85234D
Controller Settings	 85238D
Information	 85250D

Status icons

Icon	Description
------	-------------

 85262D	Motor Stopped
 85263D	Motor Stopped Wait
 85264D	Running Unloaded
 85266D	Running Unloaded Wait
 85267D	Running Loaded
 85269D	Running Loaded Wait
 85271D	Machine Control Mode, Local
 85272D	Machine Control Mode, Remote
 85273D	Machine Control Mode, LAN
 85274D	Auto Restart After Voltage Failure (ARAVF)

System icons

Icon	Description
 85276D	Basic User
 85277D	Advanced User
 85278D	Service User
 85283D	Change between screens (indication)
 85290D	Reset
	This chapter gives a general survey of available icons. Not all icons mentioned in this chapter are applicable to every machine.

Menu

Procedure

Starting from the main screen, use the left vertical swipe bar to navigate through the menu items.

Use the horizontal swipe bar to navigate through the different screens of a menu item. The page indicator



shows how many screens there are available for the current menu item, depending on the user access level.

Menu structure

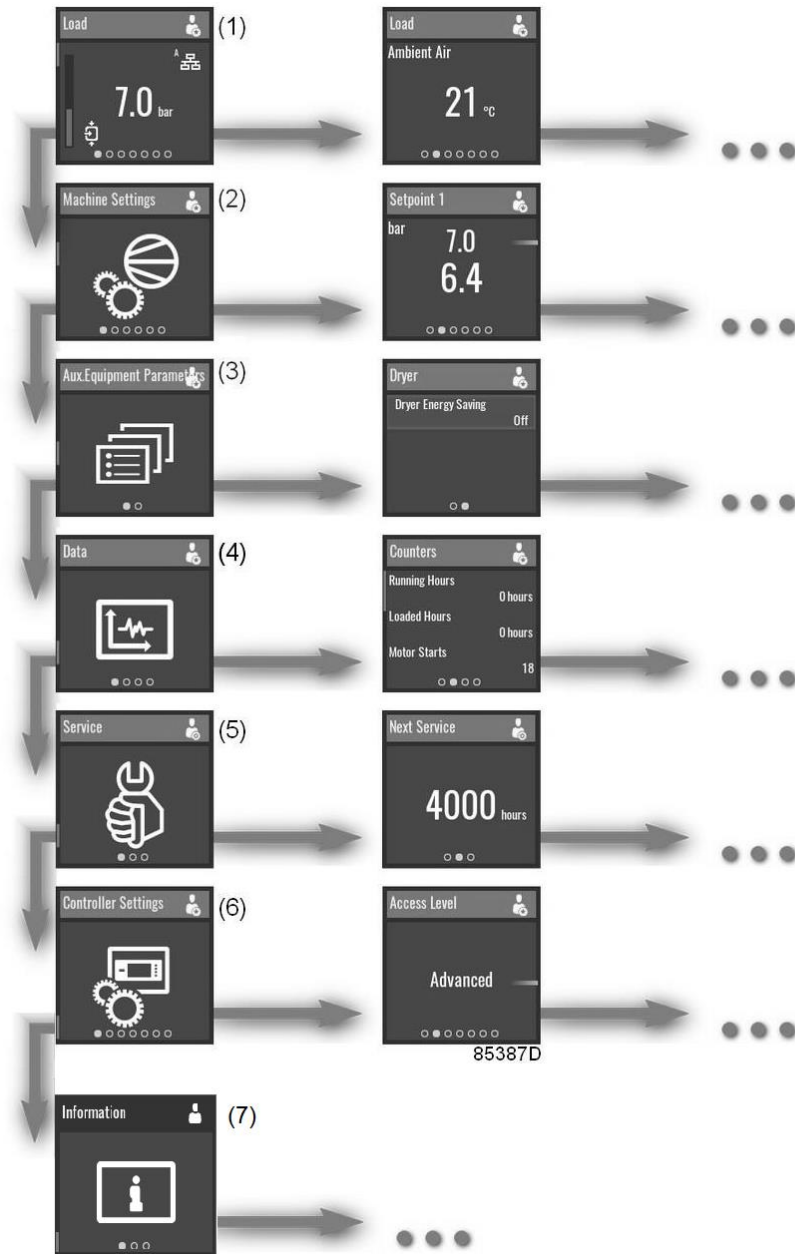

Reference	Designation	Function
(1)	Main screen	Next to the main screen, a maximum of 3 extra values can be shown.
(2)	Machine settings	Setpoints, Regulation settings and Control parameters can be viewed and modified through this menu.
(3)	Aux. Equipment parameters	Settings for auxiliary equipment can be viewed and modified through this menu. This menu is only visible when the Access level is set to Advanced. See Controller settings.
(4)	Data	The data menu contains information about the Counters, Inputs and Outputs.

(5)	Service	Information about the service interval can be found through this menu. This menu is only visible when the Access level is set to Service. See Controller settings.
(6)	Controller settings	Different controller settings, such as Access level or Ethernet settings can be viewed and modified through this menu.
(7)	Informations	Here are listed the general information on software loaded

This is the main menu structure. The structure can be different depending on the configuration of the unit.

Select or modify a setting

Several settings can be modified. The process of selecting or modifying a setting anywhere in the menu is basically the same.

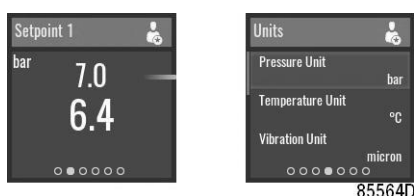

Examples of modifiable settings

Select

In these examples, the upper value is selected.

To select the lower value, swipe down on the left vertical swipe bar. **Modify**

To modify the selected value, tap the right vertical swipe bar.

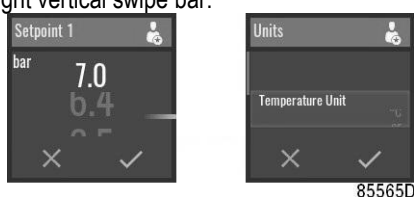

Swipe up or down on the right vertical swipebar to change the value.

On the horizontal swipebar, tap 'V' to confirm or 'X' to decline.

Main screen

Function

The Main screen is the screen that is shown automatically when the voltage is switched on. It is switched off automatically after a few minutes when there is no touch input.

Swipe left to navigate to the following screens:

- Element outlet temperature
- Dryer pressure dew-point (in case of integrated dryer only)
- Setpoint used
- Status
- Running hours (Loaded hours for compressors without integrated dryer)

Description

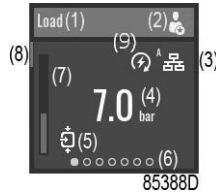

Reference	Designation	Function
(1)	Screen information	On the main screen, the screen information bar shows the current status of the machine. When scrolling through menus, the name of the current menu item is shown.
(2)	Access level icon	The access level icon shows the current access level setting. See Controller settings menu to switch between User, Advanced or Service.
(3)	Control mode icon	The control mode icon shows the current control mode setting. <ul style="list-style-type: none"> Local control via start/stop buttons Remote control via digital input(s) LAN control via the network. When in Remote or LAN control, the start/ stop buttons on the controller will not work.
(4)	Input value	This field contains an input value, depending on the type of the machine. In this case, the current outlet pressure is shown.
(5)	Status	This icon shows the current status of the unit.
(6)	Page indicator (Breadcrumbs)	Indicates how many pages there are available for a given menu item. The page which is currently active is indicated by a filled white circle. Swipe left or right to go to another screen.
(7)	Value bar	This is an indicator for the input value, also shown on the main screen. When the regulation sensor is selected 2 extra load, unload lines are shown.
(8)	Scrollbar	This is an indication of the vertical position in the menu. Swipe up or down to go to another menu item.
(9)	ARAVF icon	The ARAVF icon is shown when the Automatic Restart functionality is activated.

Parameters

Starting from the main screen, swipe left to scroll through predefined IO or counter data. (optional)



Example

Setpoint used

Starting from the main screen, swipe left until the Setpoint used screen is shown.



To switch to a different setpoint, swipe up or down on the left vertical swipe bar or tap next to the corresponding square.

Status

Starting from the main screen, swipe left until the Status screen is shown.



This screen shows the current status of the unit.

If an alarm is active, tap the right vertical swipe bar.



To reset the alarm, press the confirm button under the reset icon.

To cancel without resetting, press the cancel button under the red 'X' icon.

	<p>Before remedying, consult the Safety precautions. Before resetting a warning or shutdown message, always solve the problem. Frequently resetting these messages without remedying may damage the unit.</p>
---	--

Shutdown

Description

The unit will be shut down in following circumstances:

ENGLISH

- In case the temperature at the outlet of the element exceeds the programmed shut down level (detected by temperature sensor (TT11)).
- In case of too high oil or air/oil temperature (detected by temperature switch TSHH11 or TSHH12).
- In case of main converter fault or the fan motor overload (M2).
- In case of error of the outlet pressure sensor (PT20).

Element outlet temperature (TT11)

If the element outlet temperature, measured by temperature sensor TT11, exceeds the shutdown level (see section Programmable settings), the unit will be shutdown, alarm LED (1) will flash, automatic operation LED (3) will go out and the following screen will appear:

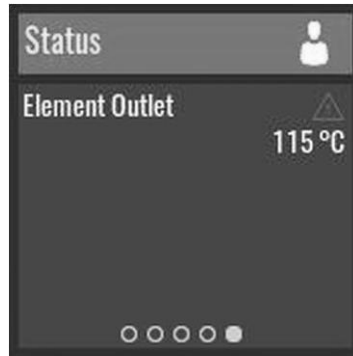

85692D

Main screen with shutdown indication, element outlet temperature

Swipe left (8) until the actual element outlet temperature appears.



85693D

Shutdown screen, element outlet temperature

The above screen shows that the temperature at the outlet of the element is 117 °C. Actions:

- Switch off the voltage and remedy the problem cause.
- After remedying and when the shutdown condition has disappeared, switch on the voltage and restart the unit.

Other shutdown causes

In case the unit is shut down (or cannot start) by one of following causes:

- Too high element outlet temperature, detected by temperature switch (TSHH11) or additional temperature switch (TSHH12).
- Main converter fault
- Fan motor overload (M2).

The unit will be shutdown, alarm LED (1) will flash, automatic operation LED (3) will go out and following screen will appear:

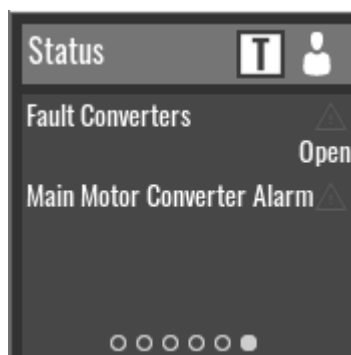

Shutdown screen, main motor converter alarm

Actions:

- Switch off the voltage and find out the problem cause:
 - In case of fan motor M2 overload protection trips contact the customer center.
 - If element outlet temperature switch has tripped (TSHH11 has tripped if aux relay K7 is open) contact the customer center.
 - If the additional temperature switch has tripped (TSHH12 has tripped if aux relay K7 is open), you must contact the customer center.
 - In case of main motor converter fault see table below.
- After remedying and when the shutdown condition has disappeared, switch on the voltage and restart the unit. The shutdown message will disappear automatically when the shutdown condition has disappeared, anyhow the controller require a reset.

Main motor converter warnings and alarms

Fault	Touch controller alarm	Fault text	Warning	Alarm	Trip Lock	Cause of problem
2		Live zero error	X	X		Signal on terminal 53 is to low. Normal when starting a unit with SWIPE+ controller (Drive is faster than controller to start up and does not receive a signal for some seconds)
4	16384	Line power ph. loss	X	X	X	Missing phase on supply side or too high voltage imbalance. Check supply Voltage.
7	2048	DC over volt	X	X		Intermediate circuit voltage exceeds the limit. Check supply voltage.
8	1024	DC under volt	X	X		Intermediate circuit voltage drops below the "voltage warning low" limit. Check supply Voltage.
9	512	Inverter overload	X	X		More than 100% load for too long. Check for mechanical overload and unloader blow off.
10	256	Motor ETR over	X	X		Motor is too hot due to more than 100% load for too long.
11	128	Motor th over	X	X		X
13	32	Overcurrent	X	X	X	Inverter peak current limit is exceeded. Check for mechanical overload, supply voltage and ambient temperature
14	4	Ground Fault		X	X	Discharge from output phases to ground. Check unit earthing and line filters.
16	4096	Short-circuit		X	X	Short-circuit in the motor or on the motor terminals.
17	16	Ctrl. word TO	X	X		No, communication to the adjustable frequency drive. Check Cable connection and Baud Rate. Only in case of Touch controller.

ENGLISH

Fault	Touch controller alarm	Fault text	Warning	Alarm	Trip Lock	Cause of problem
24		Fan Fault	X	X		The fan is not working
30		U phase loss		X	X	Motor phase U is missing. Check the phase.
31		V phase loss		X	X	Motor phase V is missing. Check the phase. .
32		W phase loss		X	X	Motor phase W is missing. Check the phase. .
36		Mains Failure	X	X		Check Supply Voltage
38		Internal fault		X	X	Contact your customer center.
44		Ground Fault		X	X	Discharge from output phases to ground.
47		Control Voltage Fault	X	X	X	24 V DC may be overloaded. Contact your service partner
48		VDD1 Supply Low		X	X	Control voltage low. Contact your service partner.
50+58		Calibration failed		X		Contact your service partner.
59		Current limit	X			The current is higher than the value in the Current Limit. It is a warning, in case of alarm unit will trip in AI 13 or 09
60		External Interlock		X		External interlock has been activated. To resume normal operation, apply 24 V DC to the terminal programmed for external interlock and reset the adjustable frequency drive (via serial communication, digital I/O, or by pressing reset button on keypad).
61		Internal fault	X	X		Contact your service partner.
63		Mech Brake low	X	X		Contact your service partner.
66		Heat Sink Temperature Low	X			This warning is based on the temperature sensor in the IGBT module (Only on 400 V 40–125 hp [30–90 kW] units).
69		Pwr. Card Temp	X	X	X	The temperature sensor on the power card is either too hot or too cold.
79		Illegal power section configuration	X	X		Internal fault. Contact your service partner.
80		Drive initialized		X		All parameter settings are reset to default settings. It is meant to track system initialization.
84		Internal fault	X	X		Contact your customer center.
85		Button disabled	x			The LCP key is disabled
86		LCP copy failed	x			Data copy failure
87		Auto DC Braking	X			The drive is auto DC braking
88		Data not compatible	X			LCP data incompatible
89		Parameter locked	x			Attempt to edit a read-only parameter
90		Internal fault	X	X		attempts to update the same parameters at the same time
94		End of curve	X	X		Contact your customer center
120		Internal fault	X	X		Contact your customer center.

IF FREQUENCY CONVERTER ALARM RESET does not work:

- Disconnect the unit from power supply for 15 minutes.
 - After power supply is restored, **RESET** frequency converter alarm on **Electronic** controller.
- If the problem is not solved, please contact the manufacturer's technical support.

Machine settings menu

Function

The Machine Settings menu provides the ability to view and modify several machine settings.

Swipe left to navigate to the following screens:

- Setpoint 1 (optional)
- Setpoint 2 (optional)
- Which setpoint is in use
- Control Mode
- Auto Restart

Procedure

To view the full Machine Settings menu Advanced access level is required:

1. Tap the Home button



on top of the screen to go to the main screen.

2. Swipe up on the left vertical swipe bar until the Machine Settings menu is shown then swipe left on horizontal bar:

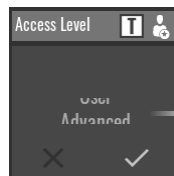

3. In Access level page swipe up the right bar to change the level from User to Advance, then confirm pushing below confirmation symbol.

Setpoint 1

Starting from the Machine Settings menu, swipe left until the Setpoint 1 screen is shown.

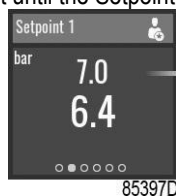

To select a load and unload setpoint, or to modify the values, see section Select or modify a setting.



Setpoint 2

Starting from the Machine Settings menu, swipe left until the Setpoint 2 screen is shown.

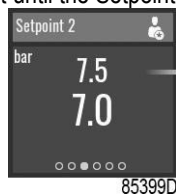

To select a load and unload setpoint, or to modify the values, see section Select or modify a setting.

Regulation

Starting from the Machine Settings menu, swipe left until the Regulation screen is shown.



To select a menu item, or to change the setting, see section Select or modify a setting.

Control Mode

Starting from the Machine Settings menu, swipe left until the Control Mode screen is shown.

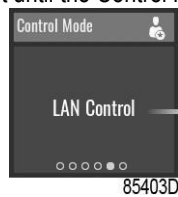

Following control modes are available:

- Local control through start/stop buttons
- Remote control through digital input(s)
- LAN control through UDP ethernet commands.

When in Remote or LAN control, the start/stop buttons on the controller will not work.

To change the setting, see section Select or modify a setting.

Auto Restart

Starting from the Machine Settings menu, swipe left until the Auto Restart screen is shown.



The controller has a built-in function to automatically restart the compressor when voltage is restored after voltage failure. This function is deactivated in compressors leaving the factory and can only be modified after entering a password, please consult your supplier to activate this function.

To select a menu item, or to change the setting, see section Select or modify a setting.

Auxiliary equipment parameters menu

Function

The Aux. Equipment parameters menu provides the ability to view and modify several settings related to the auxiliary equipment of the unit.

Swipe left to navigate to the following screens:

- Fan (Service level access is required)
- Internal or External Icons

Procedure

To view the Aux. Equipment parameters menu:

3. Tap the Home button



on top of the screen to go to the main screen.

4. Swipe up on the left vertical swipe bar until the Aux. Equipment parameters menu is shown:



SmartBox

Starting from the Aux. Equipment parameters menu, swipe left until the Internal SmartBox screen is shown.

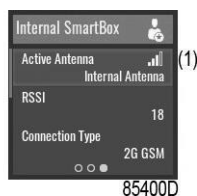

(1)

The reception quality of the internal antenna can be monitored.



To select a menu item, or to change the setting, see section [Select or modify a setting](#).

Data menu

Function

The Data menu provides the ability to view several important values.

Swipe left to navigate to the following screens:

- Counters
- Inputs
- Output
- Motor Speed

Procedure

To view the Data menu:

1. Tap the Home button



on top of the screen to go to the main screen.

2. Swipe up on the left vertical swipe bar until the Data menu is shown, without Advanced access level only a reduced screens are visible.



3. To activate Advanced full access level swipe up on the left vertical swipe bar until the Machine Settings menu is shown then swipe left:

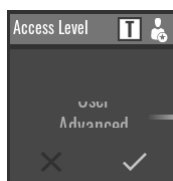

4. In Access level page swipe up the right bar to change the level from User to Advance, then confirm pushing below confirmation symbol.

Counters

Starting from the Data menu, swipe left until the Counters screen is shown.

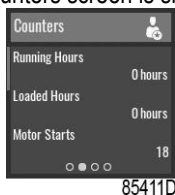

Select

To select a different item, swipe up or down on the left vertical swipe bar.

Inputs

Starting from the Data menu, swipe left until the Inputs screen is shown.



Select

To select a different item, swipe up or down on the left vertical swipe bar

Outputs

Starting from the Data menu, swipe left until the Outputs screen is shown.

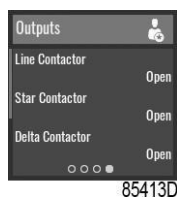

Select

To select a different item, swipe up or down on the left vertical swipe bar

Motor Speed

Starting from the Data menu, swipe left until the Motor Speed screen is shown.

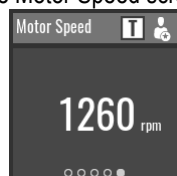

	<p>Voltage-free outputs may only be used to control or monitor functional systems. They should NOT be used to control, switch or interrupt safety related circuits. Check the maximum allowed load on the label.</p>
	<p>Stop the unit and switch off the supply before connecting external equipment. Check the Safety precautions.</p>

Service menu

Function

The Service menu provides the ability to reset the service timer. This menu is only available as Service user.

Swipe left to navigate to the following screens:

- Next service
- Safety valve test

Procedure

To view the Service menu:

1. Use the controller as a Service user access level



See Controller settings menu to change the user profile.

2. Tap the Home button



on top of the screen to go to the main screen.

3. Swipe up on the left vertical swipe bar until the Machine Settings menu is shown:

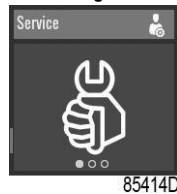

Next Service

Starting from the Service menu, swipe left until the Next Service screen is shown.

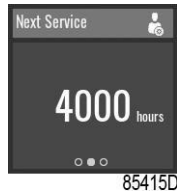

The Next Service will be triggered after the Running Hours value exceeds the Next Service value.

Reset

Tap the right vertical swipe bar, the following screen is now shown:

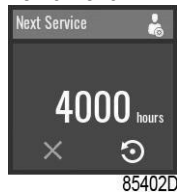

To cancel without resetting, press the cancel button under the red 'X' icon.

To reset the alarm, press the confirm button under the reset icon. The following screen is now shown:



On the horizontal swipe bar, tap 'V' to confirm or 'X' to decline.

Controller settings menu

Function

The Controller Settings menu provides the ability to view and modify several settings of the controller.

Swipe left to navigate to the following screens:

- Access Level
- Language
- Units
- CAN Settings
- Ethernet Settings
- Display Timeout

Procedure

To view the Controller Settings menu:

1. Tap the Home button



on top of the screen to go to the main screen.

2. Swipe up on the left vertical swipe bar until the Controller Settings menu is shown:

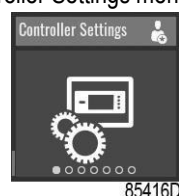

Access Level

Starting from the Controller Settings menu, swipe left until the Access Level screen is shown.

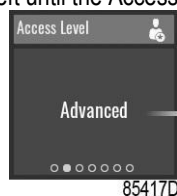

To modify the setting, see section [Select or modify a setting](#).



Enter a password

The Service user profile is protected by a password. After selecting the Service user profile, the following screen pops up:



The user can enter the password by swiping up or down on the right vertical swipe bar to select the first digit.

Tap '→' to be able to enter the second digit.

Once the 4 digits are entered, the user can confirm by tapping 'V' or decline by tapping 'X'.

ENGLISH

Language

Starting from the Controller Settings menu, swipe left until the Language screen is shown.



To modify the setting, see section [Select or modify a setting](#).

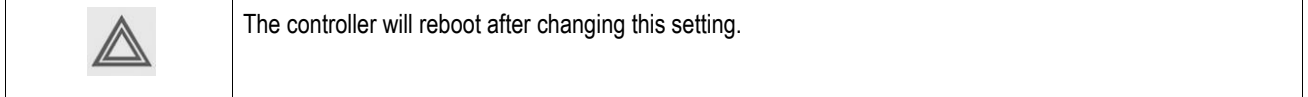

Units

The units displayed can be modified through this menu.

CAN Settings

The list of CAN Settings is shown. When CAN is turned off, the settings can be modified.

Ethernet Settings

The list of Ethernet Settings is shown. When ethernet is turned off, IP address, Subnet mask and Gateway can be modified.

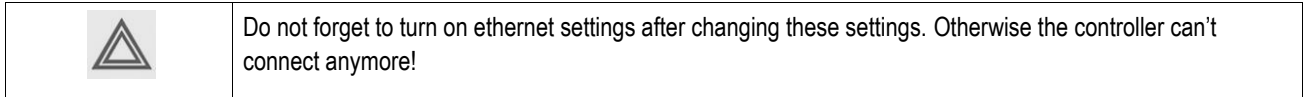

Display Timeout

Starting from the Controller Settings menu, swipe left until the Display Timeout screen is shown.

Display timeout is used to save energy and save the lifetime of the display. Timer starts after last operator actions on the push buttons or swipe bars.

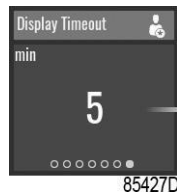

To modify the setting, see section [Select or modify a setting](#).

Information menu

Function

The Information menu provides the ability to view important information.

Swipe left to navigate to the following screens:

- Help
- Information about Mac address and software version loaded.

Procedure

To view the Information menu:

1. Tap the Home button



on top of the screen to go to the main screen.

2. Swipe up on the left vertical swipe bar until the Information menu is shown:

Help

Starting from the Information menu, swipe left until the Help screen is shown.

The manufacturer's website is shown.

Info

Starting from the Information menu, swipe left until the Info screen is shown.

Following items are displayed:

- Mac Address
- Application Description
- Application Software: nr + version
- Operation: nr + version
- BOOT Software: nr

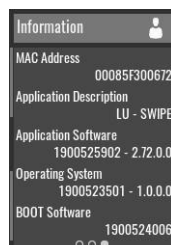

Parameters

		Minimum setting	Factory setting	Maximum setting
Manual/Remote Stop time	sec	30	30	30
Unload to Stop time	sec	180	180	180
Minimum stop time	sec	10	20	30
Restart (ARAVF)	sec	60	60	1200

Protections

		Minimum setting	Factory setting	Maximum setting
Compressor element outlet temperature (shutdown warning level)	°C	50	110	114
Compressor element outlet temperature (shutdown warning level)	°F	122	230	237
Compressor element outlet temperature (shutdown level)	°C	110	115	115
Compressor element outlet temperature (shutdown level)	°F	230	239	239

Service plan

The built-in service timer will give a Service warning message after a pre-programmed time interval has elapsed.

Also see section Preventive maintenance schedule.

Consult customer center if a timer setting has to be changed. See section Calling up/modifying service timer settings.

The intervals must not exceed the nominal intervals and must coincide logically.

ENGLISH**Terminology**

Term	Explanation
ARAVF	Automatic restart after voltage failure. See section Elektronikon regulator and Activating automatic restart .
Restart delay	This parameter allows to program that not all compressors are restarted at the same time after a power failure (ARAVF active).
Compressor element outlet	The regulator does not accept inconsistent settings, e.g. if the warning level is programmed at 95 °C (203 °F), the minimum limit for the shutdown level changes to 96 °C (204 °F). The recommended difference between the warning level and shutdown level is 10 °C (18 °F).
Delay at shutdown signal	Is the time for which the signal must exist before the compressor is shutdown. If it is required to program this setting to another value, consult customer center.
Minimum stop time	Once the compressor has automatically stopped, it will remain stopped for the minimum stop time, whatever happens with the net air pressure. Consult customer center if a setting lower than 20 seconds is required.
Unloading/ Loading pressure	The regulator does not accept illogical settings, e.g. if the unloading pressure is programmed at 7.0 bar(e) (101 psi(g)), the maximum limit for the loading pressure changes to 6.9 bar(e) (100 psi(g)). The recommended minimum pressure difference between loading and unloading is 0.6 bar (9 psi(g)).

14.5 TOUCH CONTROLLER (Available only as OPTION for both Fix Speed and VSD units)

Introduction

The electronic controller has following functions:

- Controlling the compressor
- Protecting the compressor
- Monitoring components subject to service
- Automatic restart after voltage failure (option)



Automatic control of the compressor

The controller maintains the net pressure between programmable limits by automatically loading and unloading the compressor in case of fixed speed machines. For VSD machines the controller also modifies the motor speed in order to maintain the setpoint pressure. A number of programmable settings, e.g. the unloading and loading pressures, the minimum stop time and the maximum number of motor starts are taken into account.

The controller stops the compressor whenever possible to reduce the power consumption and restarts it automatically when the net pressure decreases. If the expected unloading period is too short, the compressor is kept running to prevent too short stand-still periods.

Protecting the compressor

Shut-down

The compressor will be stopped, and it will be indicated on the display in the following events:

- Compressor element outlet temperature bigger than the programmed shut-down level detected by temperature sensor
- Compressor element outlet temperature bigger than the programmed shut-down level detected by temperature switch
- Overload of the drive (converter) or main motor
- Overload of the fan motor
- Incorrect supply sequence (Only for fixed speed machines and all machines with dryer).
- Failure inverter (Only for VSD machines)
- Additional thermostat operation.
- Pressure sensor error.

Example: Temperature sensor error on air outlet of compressor unit. In chapter "Shut-down visualization" it's explained how it appears on the display, how to recognize which is the shut-down and how to solve it.

Shut-down warning

A shut-down warning level is a programmable level below the shut-down level. If one of the measurements exceeds the programmed shut-down warning level, this will also be indicated to warn the operator before the shut-down level is reached. The shut-down warning appears in case of:

- Too high temperature at the compressor element outlet
- Too high dew-point temperature for dryer equipped units
- Too high pressure at the compressor element outlet

Example: Too high dew-point temperature for dryer equipped units. In chapter "Shut-down warning visualization" it's explained how it appears on the display, how to recognize which is the warning and how to solve it.

Service warning

If the service timer exceeds a programmed value, this will be indicated on the display to warn the operator to carry out some service actions.

Automatic restart after voltage failure (ARAVF).

The controller has a built-in function to automatically restart the compressor when the voltage is restored after voltage failure.

The function is not active. To activate it please contact the customer centre.



Provided the controller is in the automatic restart mode, the compressor will automatically restart when the supply voltage to the module is restored.

Control panel

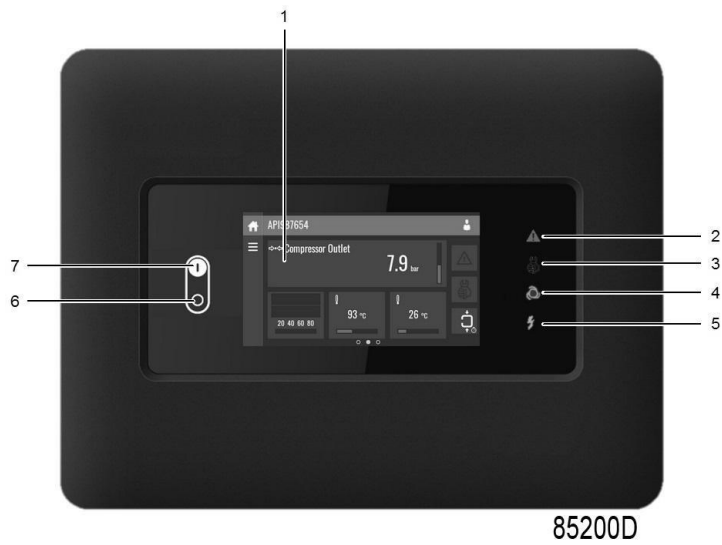

FIG. 15

Function keys of the controller

















Reference	Designation	Function
1	Touchscreen	Shows the unit operating condition and a number of icons to navigate through the menu. The screen can be operated by touch.
2	Warning sign	Flashes in case of a shut-down, is lit in case of a warning condition.
3	Service sign	Is lit when service is needed.
4	Operation sign	Is lit when the unit is running in automatic operation.
5	Voltage sign	Indicates that the voltage is switched on.
6	Stop button	This button stops the unit.
7	Start button	This button starts the unit. The operation sign (4) lights up. The controller is operative.























CAUTION: WAIT AT LEAST 20 SECONDS BEFORE STARTING THE MACHINE AFTER SWITCH OFF.

CAUTION: IN CASE OF START UP OR RESTART AFTER EMERGENCY STOP /ARAVF/ SHUT DOWN (SEE INSTRUCTION BOOK), REFRIGERANT DRYER WILL RUN AFTER A DELAY OF 180 SECONDS.

Menu icons

Menu	Icon	Menu	Icon	Menu	Icon
Data	 85233D	Status	 85239D		
		Inputs	 85240D		
		Outputs	 85241D		
		Counters	 85242D		
		Aux. Equipment Parameters	 85243D		
Service	 85234D	Service		Overview	 85252D
				Service Plan	 85253D
				Service History	 85254D
		Service functions	 85244D		
Clean Screen	 85302D				
Week Timer	 85235D			Week	 85303D
				Remaining Running Time	 85304D
Event History	 85236D	Saved Data	 85245D		

Menu	Icon	Menu	Icon	Menu	Icon
Machine Settings	 85237D	Alarms	 85239D		
		Regulation	 85346D		
		Control Parameters	 85347D		
		Aux. Equipment Parameters	 85243D	Converter(s)	 85251D
				Fan	 85255D
				Internal SmartBox	 85246D
Auto Restart	 85274D				
Controller Settings	 85238D	Network Settings	 85246D	Ethernet Settings	 85257D
				CAN Settings	 85258D
		Localisation	 85247D	Language	 85259D
				Date/Time	 85260D
				Units	 85261D
		User Password	 85248D		
		Help	 85249D		
		Information	 85250D		



Status icons

Icon	Description
 85262D	Motor Stopped
 85263D	Motor Stopped Wait
 85264D	Running Unloaded
 85265D	Manual Unload
 85266D	Running Unloaded Wait
 85267D	Running Loaded
 85268D	Failed to Load
 85269D	Running Loaded Wait
 85270D	Manual Stop
 85271D	Machine Control Mode, Local
 85272D	Machine Control Mode, Remote
 85273D	Machine Control Mode, LAN
 85274D	Automatic Restart After Voltage Failure
 85275D	Week Timer Active







ENGLISH

System icons

Icon	Description
 85276D	Basic User
 85277D	Advanced User
 85278D	Service User
 85279D	Antenna 25%
 85280D	Antenna 50%
 85281D	Antenna 75%
 85282D	Antenna 100%
 85283D	Change between screens (indication)
 85284D	Energy recovery
 85285D	Dryer
 85286D	Element
 85287D	Drain(s)
 85288D	Analogue Output
 85289D	Menu
 85290D	Reset
 85291D	Auto Restart
 85292D	Filter(s)

 85293D	Cooler
 85294D	Valve(s)
 85295D	Power Meter

Input icons

Icon	Description
 85296D	Pressure
 85297D	Temperature
 85298D	Special Protection
 85299D	Open
 85300D	Closed
	This chapter gives a general survey of available icons. Not all icons mentioned in this chapter are applicable to every machine.

Main screen

Function

The Main screen is the screen that is shown automatically when the voltage is switched on. It is switched off automatically after a few minutes when there is no touch input.

Description

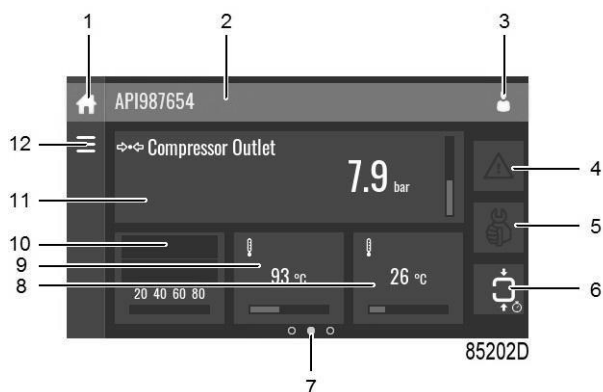

Reference	Designation	Function
1	Home button	The home button is always shown and can be tapped to return to the main screen.
2	Screen information	On the main screen, the screen information bar shows the serial number of the machine. When scrolling through menus, the name of the current menu is shown.
3	Access level button	The access level button is always shown and can be tapped to change the current user access level.
Reference	Designation	Function
4	Alarm button	The alarm button can be tapped to show the current alarms. If an alarm occurs, the icon on the button will be red.
5	Service button	The service button can be tapped to show the service information.
6	Status	This icon shows the current status of the unit.
7	Page indicator	Indicates which page you currently see. The middle indication is the main screen, left is the menu screen and at the right the quick access screen. Swipe left or right to go to another screen.
8, 9, 10, 11	These fields can contain a history chart, an input or a counter value, depending on the type of the machine.	Tap the field to view the type of measurement. This will be shown in the screen information bar. Examples of inputs: <ul style="list-style-type: none"> • Outlet Pressure • Oil temperature • Dryer dewpoint Examples of counters: <ul style="list-style-type: none"> • Running hours • Load relay • Loaded hours

12	Menu button	The menu button is always shown and can be tapped to go to the menu.
----	-------------	--

Quick access screen

Function

The screen is used to directly access some frequently used functions.

Procedure

The Quick access screen can be viewed by swiping left, starting from the main screen.

Description



Through this screen, several important settings can be viewed and modified.

Function	Description
Setpoints	Several setpoints can be modified by tapping this icon.
Control mode	The control mode can be changed by tapping this icon. <ul style="list-style-type: none"> Local control via start/stop buttons Remote control via digital input(s)
Display language	The display language of the controller can be changed by tapping this icon.
Manual unload (only on fixed speed units)	When tapped, the machine will go in Manual unload mode until the icon is tapped again.
Week timer	Week timers can be set by tapping this icon.
Remaining running time	The Remaining running time can be set and modified by tapping this icon.
Internal SmartBox	<p>The reception quality of the internal antenna can be monitored.</p>  <p>Each bar represents 25% reception strength. If the four bars are filled, the reception strength is 100%. If only one bar is filled, the reception strength is just 25%.</p>
Auto restart	Auto restart can be activated by tapping this icon.

Shutdown warning

If the element outlet temperature exceeds the shutdown warning level (see section Programmable Settings), warning LED (2) will light up and a yellow warning icon (4) is shown in the upper side of the display as in below image:

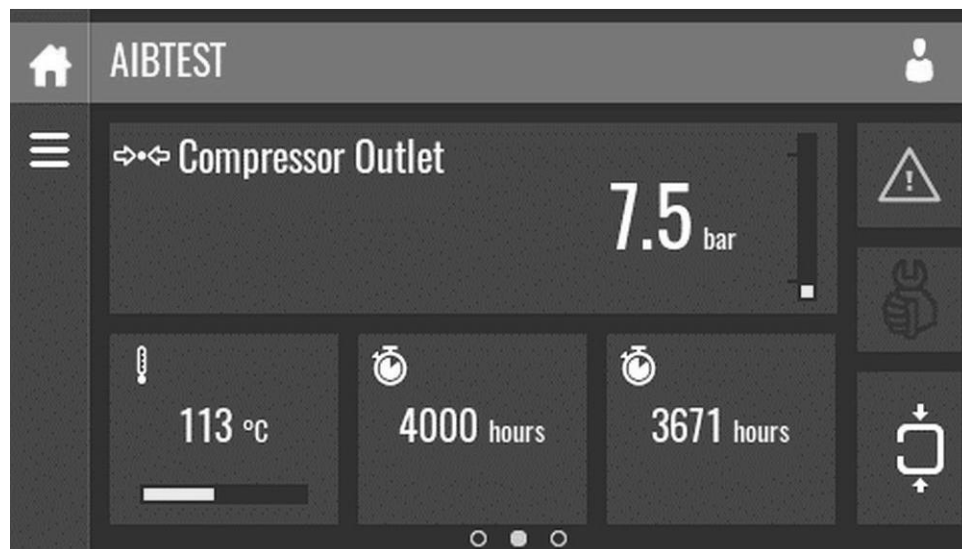

85695D

Tap on the select warning icon (4) to see the Status menu.

In case of element outlet temperature warning, the display will appear as below:

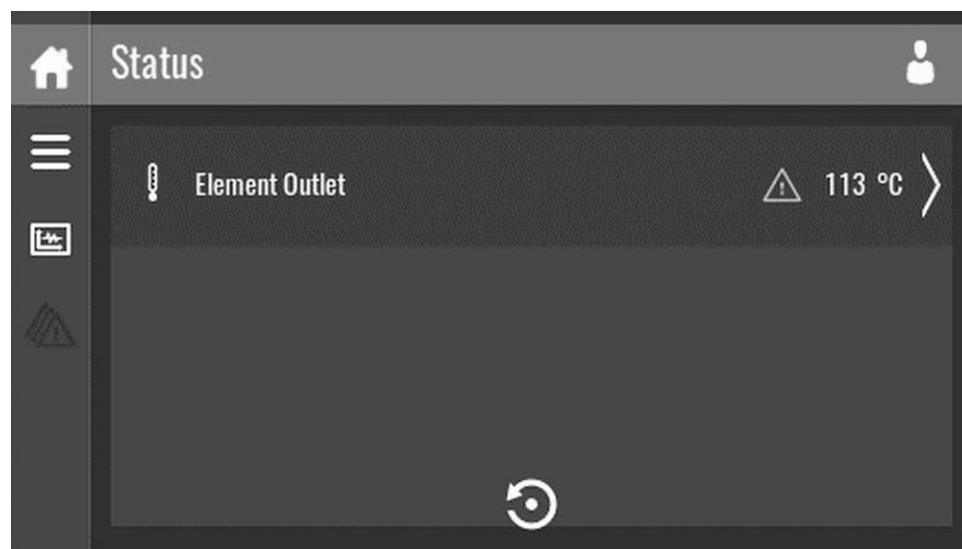

85696D

It remains possible to scroll through other screens, to check the actual status of other parameters. Press stop key (7) to stop the unit and wait until the unit has stopped. Switch off the voltage, inspect the unit and remedy. The warning message will disappear as soon the warning condition disappears.

Shutdown

Description

The unit will be shut down in following circumstances:

- In case the temperature at the outlet of the element exceeds the programmed shut down level (detected by temperature sensor (TT11)).
- In case the main temperature switch (TSHH11) open for too high oil temperature detected .
- In case of too high air/oil temperature (detected by additional temperature switch (TSHH12)).
- In case of overload of the motor (M1 - Only Fix Speed units) or the fan motor (M2).
- In case of converter fault or alarm (Converter units only)
- In case of error of the outlet pressure sensor (PT20).
- In case of incorrect phase sequence, detected by phase sequence relay (K25) (Only Fix Speed units).

Element outlet temperature (TT11)

If the element outlet temperature, measured by temperature sensor TT11, exceeds the shutdown level (see section Programmable settings), the unit will be shutdown, alarm LED (2) will flash, automatic operation LED (4) will go out and the following screen will appear:

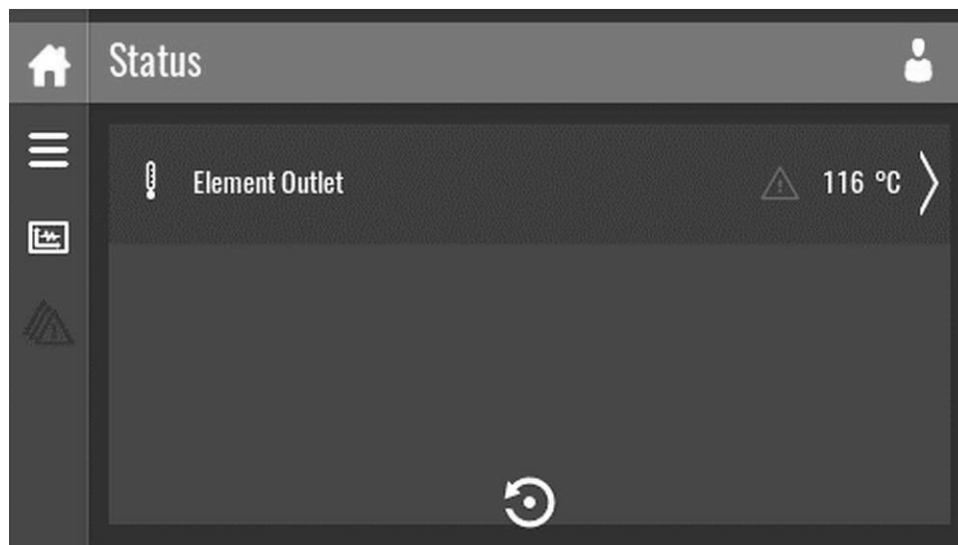

85697D

Status screen with shutdown indication

Press on shutdown indication on the screen.

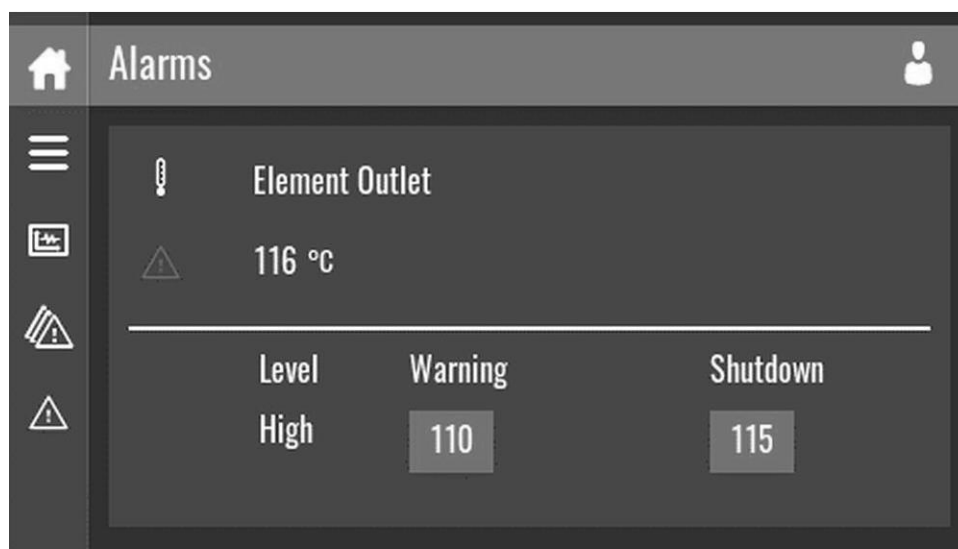

85698D

Shutdown screen, element outlet temperature

The above screen shows that the temperature at the outlet of the element is 116 °C. Actions:

- Switch off the voltage and remedy the problem cause.
- After remedying and when the shutdown condition has disappeared, switch on the voltage, reset the alarm and restart the unit.

Other shutdown causes

In case the unit is shut down (or cannot start) by one of following causes:

- Too high element outlet temperature detected by temperature switch (TSHH11) or additional temperature switch (TSHH12).
- Overload of the motor (M1 - only fix speed units) or the fan motor (M2).
- Incorrect phase sequence detected by phase sequence relay (K25).
- Main converter alarm (Only variable speed units)

The unit will be shutdown, alarm LED (2) will flash, automatic operation LED (4) will go out and following screen will appear:

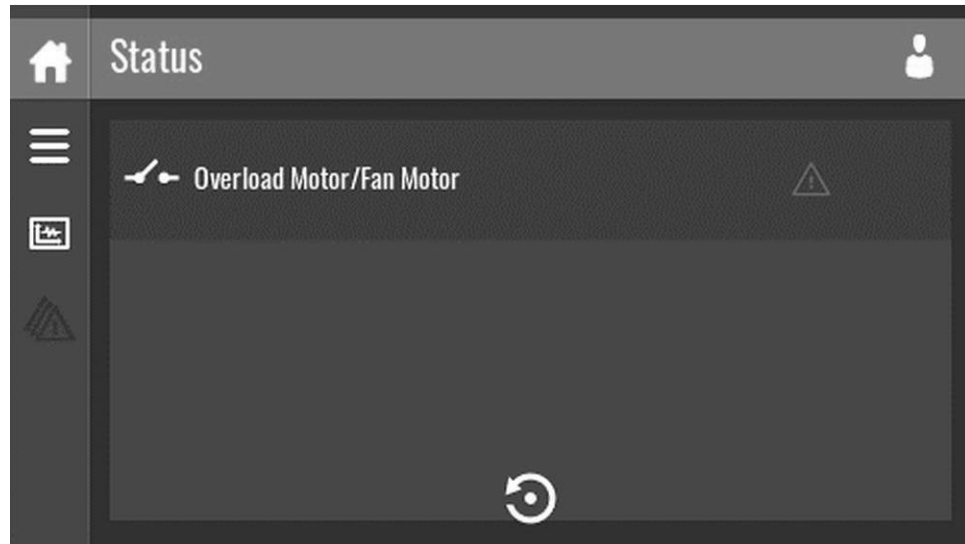

85699D

Main screen with shutdown indication

Actions:

- Switch off the voltage and remedy the problem cause.
- In case of incorrect phase sequence, reverse two phases of the supply cable.
- If the additional temperature switch (TSHH12) has tripped, you must contact the customer center.
- In case of M1 overload trip or main converter alarm you must contact the customer center
- After remedying and when the shutdown condition has disappeared, switch on the voltage and restart the unit.
The shutdown message will disappear automatically when the shutdown condition has disappeared.

IF FREQUENCY CONVERTER ALARM RESET does not work:

- Disconnect the unit from power supply for 15 minutes.
 - After power supply is restored, **RESET** frequency converter alarm on **Electronic** controller.
- If the problem is not solved, please contact the manufacturer's technical support.

Warnings and alarms

Fault	Touch controller alarm	Fault text	Warning	Alarm	Trip Lock	Cause of problem
2		Live zero error	X	X		Signal on terminal 53 is to low. Normal when starting a unit with SWIPE+ controller (Drive is faster than controller to start up and does not receive a signal for some seconds)
4	16384	Line power ph. loss	X	X	X	Missing phase on supply side or too high voltage imbalance. Check supply Voltage.
7	2048	DC over volt	X	X		Intermediate circuit voltage exceeds the limit check supply voltage.
8	1024	DC under volt	X	X		Intermediate circuit voltage drops below the "voltage warning low" limit. Check supply Voltage.
9	512	Inverter overload	X	X		More than 100% load for too long. Check for mechanical overload and unloader blow off.
10	256	Motor ETR over	X	X		Motor is too hot due to more than 100% load for too long.
11	128	Motor th over	X	X		X
13	32	Overcurrent	X	X	X	Inverter peak current limit is exceeded. Check for mechanical overload, supply voltage and ambient temperature
14	4	Ground Fault		X	X	Discharge from output phases to ground. Check unit earthing and line filters.
16	4096	Short-circuit		X	X	Short-circuit in the motor or on the motor terminals.
17	16	Ctrl. word TO	X	X		No, communication to the adjustable frequency drive. Check Cable connection and Baud Rate.
24		Fan Fault	X	X		The fan is not working
30		U phase loss		X	X	Motor phase U is missing. Check the phase.
31		V phase loss		X	X	Motor phase V is missing. Check the phase. .
32		W phase loss		X	X	Motor phase W is missing. Check the phase. .
36		Mains Failure	X	X		Check Supply Voltage
38		Internal fault		X	X	Contact your customer center.
44		Ground Fault		X	X	Discharge from output phases to ground.
47		Control Voltage Fault	X	X	X	24 V DC may be overloaded. Contact your service partner
48		VDD1 Supply Low		X	X	Control voltage low. Contact your service partner.
50÷58		Calibration failed		X		Contact your service partner.
59		Current limit	X			The current is higher than the value in the Current Limit. It is a warning, in case of alarm unit will trip in Al 13 or 09
60		External Interlock		X		External interlock has been activated. To resume normal operation, apply 24 V DC to the terminal programmed for external interlock and reset the adjustable frequency drive (via serial communication, digital I/O, or by pressing reset button on keypad).
61		Internal fault	X	X		Contact your service partner.
63		Mech Brake low	X	X		Contact your service partner.
66		Heat Sink Temperature Low	X			This warning is based on the temperature sensor in the IGBT module (Only on 400 V 40–1 25 hp [30–90 kW] units).
69		Pwr. Card Temp	X	X	X	The temperature sensor on the power card is either too hot or too cold.
79		Illegal power section configuration	X	X		Internal fault. Contact your service partner.
80		Drive initialized		X		All parameter settings are reset to default settings. It is meant to track system initialization.
84		Internal fault	X	X		Contact your customer center.
85		Button disabled	x			The LCP key is disabled
86		LCP copy failed	x			Data copy failure
87		Auto DC Braking	X			The drive is auto DC braking
88		Data not compatible	X			LCP data incompatible
89		Parameter locked	x			Attempt to edit a read-only parameter

Fault	Touch controller alarm	Fault text	Warning	Alarm	Trip Lock	Cause of problem
90		Internal fault	X	X		attempts to update the same parameters at the same time
94		End of curve	X	X		Contact your customer center
120		Internal fault	X	X		Contact your customer center.

Menu screen

Function

This screen is used to display the different menus where settings can be viewed or changed.

Procedure

The Menu screen can be viewed by tapping the Menu button or by swiping right, starting from the main screen.

Description

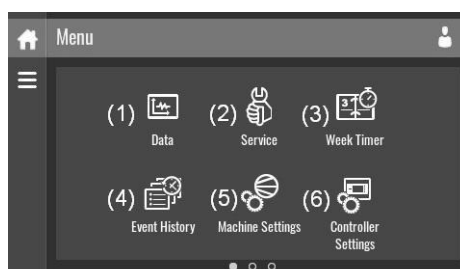

85204D

Reference	Designation	Function
(1)	Data	The data menu contains the status of the unit, information about the Inputs, Outputs and Counters. The Auxiliary equipment can also be viewed through this menu.
(2)	Service	The service menu contains the Service information. The 'Clean screen' function can be used to clean the touchscreen.
(3)	Week timer	Multiple Week timers and a Remaining running time can be set through this menu.
(4)	Event history	In case of an alarm, the Status information of the unit is saved and can be viewed through this menu.
(5)	Machine settings	Alarms settings, Regulation settings and Control parameters can be changed through this menu. Auxiliary equipment parameters can also be changed. The Auto restart function can be set through this menu. This function is password protected.
(6)	Controller settings	Network settings, Localisation settings and a User password can be set through this menu. There is also a Help page available and the Controller information can be shown.

Menu structure

Operating the controller can be done by swiping through screens and tapping icons or menu items.

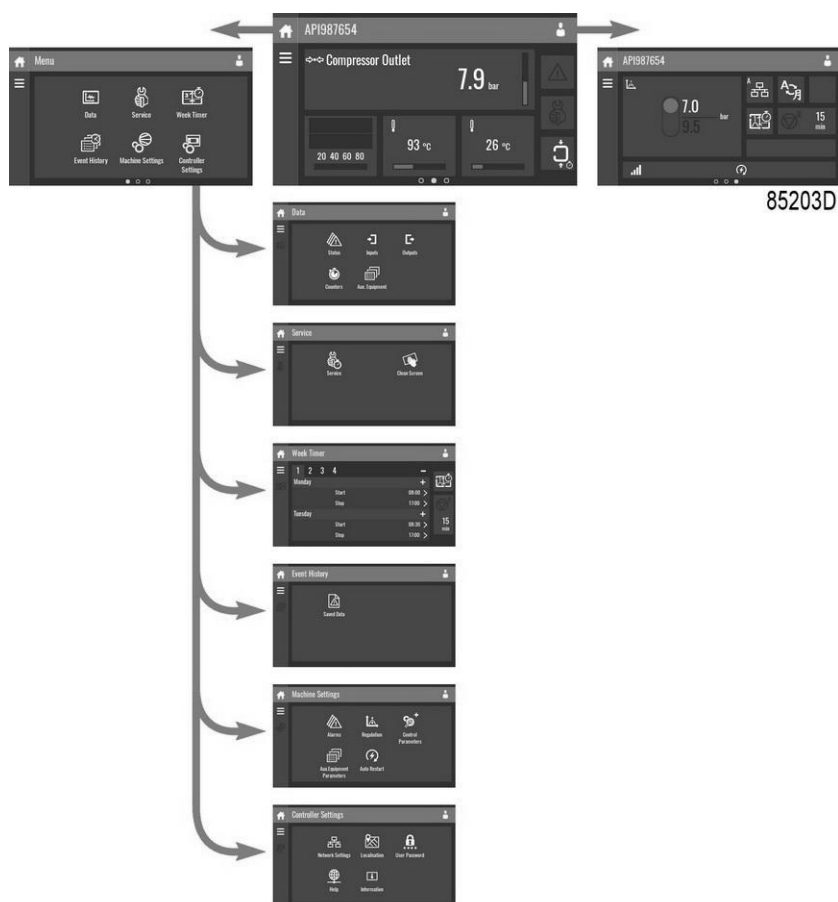

This is the main menu structure. The structure can be different depending on the configuration of the unit.

Data menu

Function

This screen is used to display the following submenus:

- Status
- Inputs
- Outputs
- Counters
- Aux. Equipment

These submenus can be entered by tapping the icons.

Procedure

To enter the Data menu screen:

1. Tap the Menu button
2. Tap the Data icon

Description

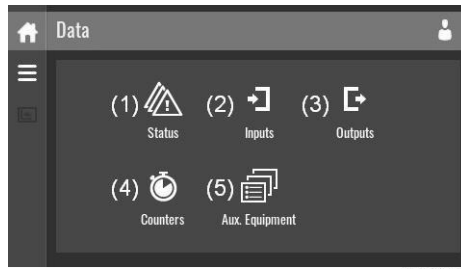

85210D

Reference	Designation
(1)	Status menu
(2)	Inputs menu
(3)	Outputs menu
(4)	Counters menu
(5)	Auxiliary equipment menu

Status menu

Tap the Status icon to enter the Status menu.

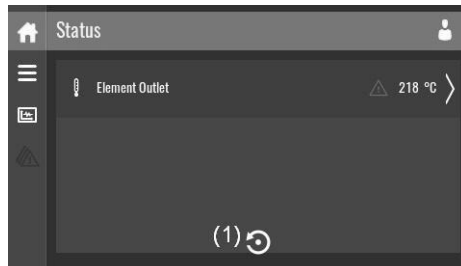

85205D

This menu shows the current status of the unit.

If an alarm is active, it can be viewed by tapping the alarm message. To reset an alarm, tap the reset button (1).

	<p>Before remedying, consult the Safety precautions.</p> <p>Before resetting a warning or shutdown message, always solve the problem. Frequently resetting these messages without remedying may damage the unit.</p>
---	--

Inputs menu

Tap the Inputs icon to enter the Inputs menu.

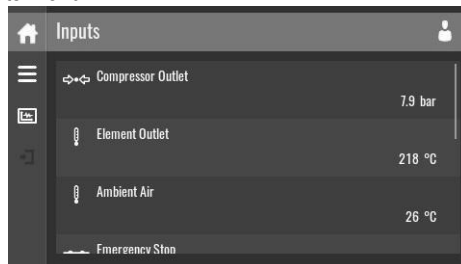

85206D

This menu shows information about all the inputs.

Outputs menu

Tap the Outputs icon to enter the Outputs menu.

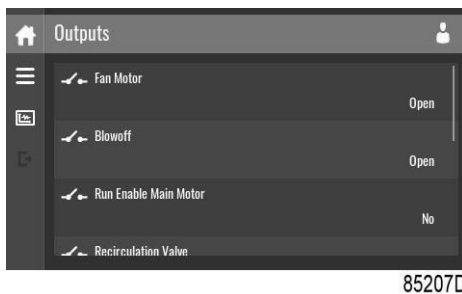

85207D

This menu shows information about all the outputs.

	<p>Voltage-free outputs may only be used to control or monitor functional systems. They should NOT be used to control, switch or interrupt safety related circuits. Check the maximum allowed load on the label.</p>
	<p>Stop the unit and switch off the supply before connecting external equipment. Check the Safety precautions.</p>

Counters menu

Tap the Counters icon to enter the Counters menu.

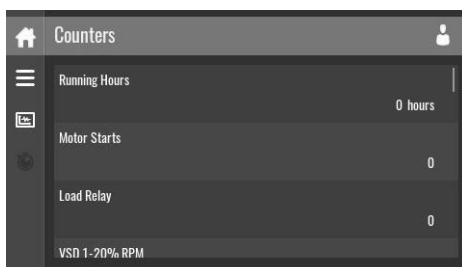

85208D

This menu shows an overview of all actual hours and counters of the unit and controller.

Auxiliary equipment menu

Tap the Aux. Equipment icon to enter the Aux. equipment menu.

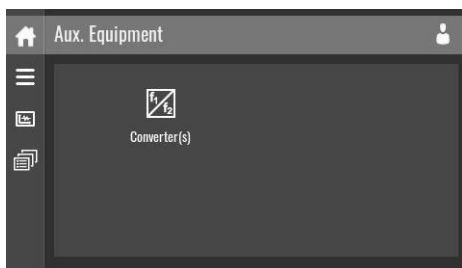

85209D

This menu shows an overview of all auxiliary equipment fitted.

Service menu

Function

This screen is used to display the following submenus:

- Service
- Service functions (Only visible as advanced user)
- Clean screen

These submenus can be entered by tapping the icons.

Procedure

To enter the Service menu screen:

1. Tap the Menu button
2. Tap the Service icon

Description

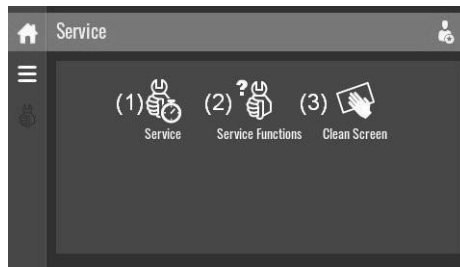

85213D

Reference	Designation
(1)	Service
(2)	Service functions (Only visible as advanced user)
(3)	Clean screen

Service menu

Tap the Service icon to enter the Service menu.

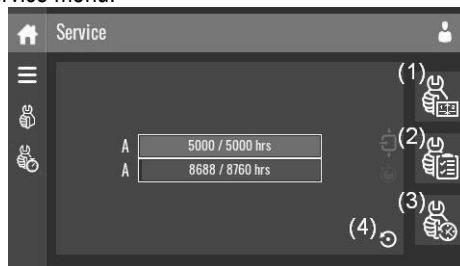

85211D

This menu shows the remaining Running Hours and the remaining Real Time Hours until the next service. The first row (A) shows the Running Hours when the first service is needed (green), the second row shows the Real Time Hours (blue)

A service overview can be viewed by tapping icon (1).

The service plan can be viewed by tapping icon (2). Through this menu, the service plan can be modified:

1. Tap the desired service plan. A selection screen will pop up.
2. Change the Running Hours by tapping '-' or '+'.
3. Confirm by tapping 'V' or decline by tapping 'X'.

The service history can be viewed by tapping icon (3).

When a service plan interval is reached, a message will appear on the screen. When service has been performed, the service timer can be reset by tapping the reset button (4).

Service functions (Only visible as advanced user)

Tap the Service Functions icon to enter the Service Functions menu.

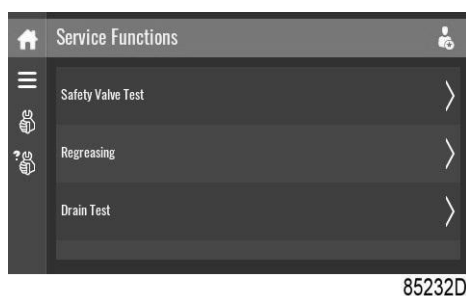

Depending on the machine, this menu can have a different set of functions. Many of them are password protected, as they are only accessible for authorized personnel.

Clean screen

Tap the Clean Screen icon to start the 15 seconds countdown to perform cleaning of the touchscreen.

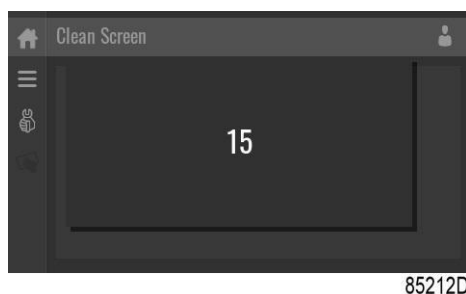

The touchscreen and the start and stop button become inactive for 15 seconds.

Week timer menu

Function

This screen is used to set up to 4 different week timers with each up to 8 settings per day.

The week timers can be activated through this screen.

A Remaining Running Time can be set from 5 up to 240 minutes.

Procedure

To enter the Week Timer menu screen:

1. Tap the Menu button
2. Tap the Week Timer icon

Description

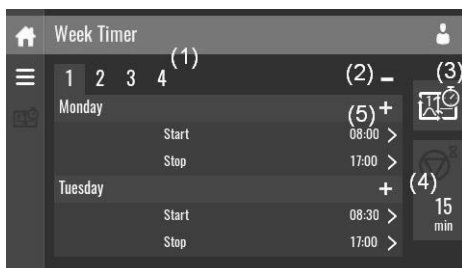

85214D

Reference	Designation	Function
(1)	Add or select week	If less than 4 weeks are programmed, tap the '+' button to add a week.
(2)	Remove week	Tap to remove a programmed week timer.
(3)	Activate week timer	A selection screen pops up. The user can choose the correct week by tapping '-' or '+' and can confirm by tapping 'V' or decline by tapping 'X'.
(4)	Remaining running time	A selection screen pops up. The user can change the remaining time by tapping '-' or '+' and can confirm by tapping 'V' or decline by tapping 'X'.
(5)	Add setting	A selection screen pops up. The user can change the setting by swiping up or down and confirm by tapping 'V' or decline by tapping 'X'.

Event history menu

Function

This screen is used to display the saved data in case of an alarm.

These submenus can be entered by tapping the icons.

Procedure

To enter the Event history menu screen:

1. Tap the Menu button
2. Tap the Event History icon

Description

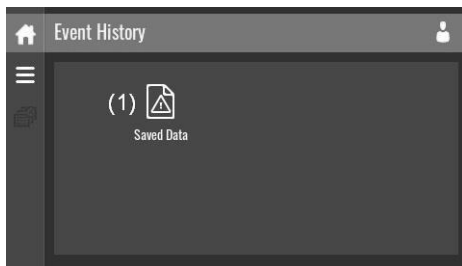

85216D

Reference	Designation
(1)	Saved Data

Saved data

Tap the Saved Data icon to enter the Saved Data menu.

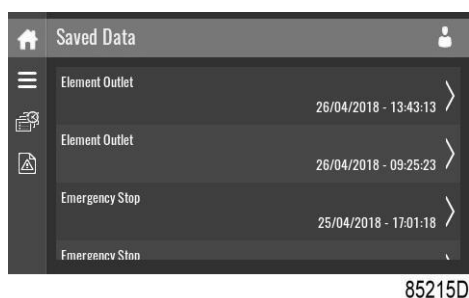

Scroll through the items swiping up and down in this list. The event date and time is shown at the right side of the screen.

Press on one of the items in the list for more information reflecting the status of the unit when the shutdown occurred.

Machine settings menu

Function

This screen is used to display the following submenus:

- Alarms
- Regulation
- Control Parameters
Only visible if the machine has adaptable parameters.
- Aux. Equipment parameters
- Auto Restart

These submenus can be entered by tapping the icons.

Procedure

To enter the Machine settings menu screen:

1. Tap the Menu button
2. Tap the Machine Settings icon

Description

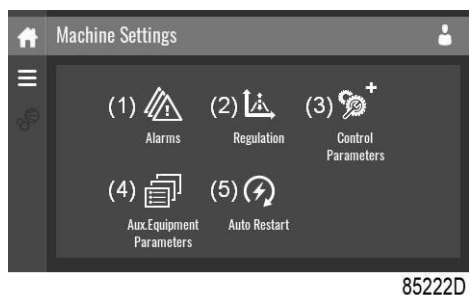

Reference	Designation
(1)	Alarms menu
(2)	Regulation menu
(3)	Control Parameters menu
(4)	Aux. Equipment Parameters menu
(5)	Auto Restart menu

Alarms menu

Tap the Alarms icon to enter the Alarms menu.

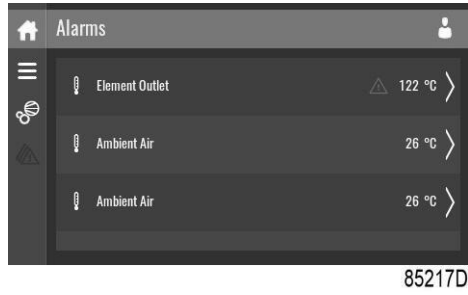

A list of all alarms is shown.

When pressing on one of the items in this list, the warning and/or shutdown levels are shown for this alarm.

Regulation menu

Tap the Regulation icon to enter the Regulation menu.

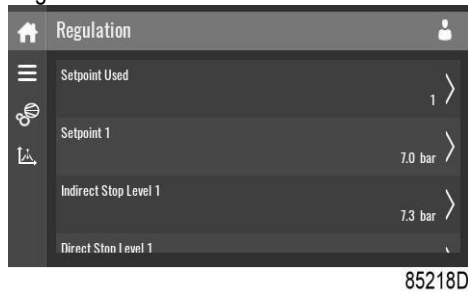

Setpoints or pressure bands can be modified through this menu.

Modify a setting

When tapping a list item, a selection screen pops up. The user can modify the setting by tapping '-' or '+' and can confirm by tapping 'V' or decline by tapping 'X'.

Change a selection

When tapping a list item, a selection screen pops up. The user can change the selection by swiping up or down and confirm by tapping 'V' or decline by tapping 'X'.

Control parameters menu

Tap the Control Parameters icon to enter the Control Parameters menu.

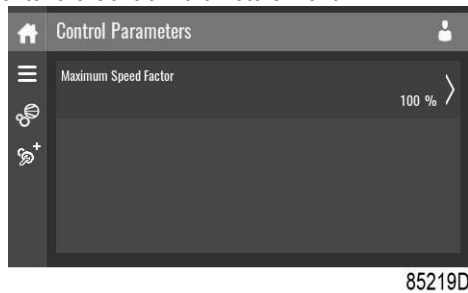

This menu shows information about the Control Parameters.

Modify a setting

When tapping a list item, a selection screen pops up. The user can modify the setting by tapping '-' or '+' and can confirm by tapping 'V' or decline by tapping 'X'.

Auxiliary equipment parameters menu

Tap the Aux. Equipment Parameters icon to enter the auxiliary equipment parameters menu.

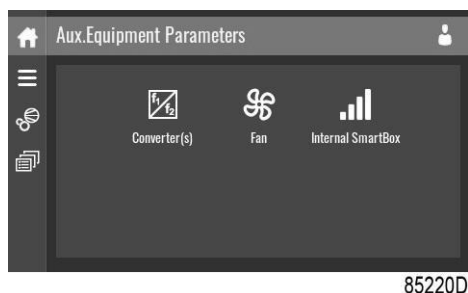

85220D

This menu shows an overview of all the auxiliary equipment fitted.

Through this menu, the parameters of the auxiliary equipment can be changed.

Modify a setting

When tapping a list item, a selection screen pops up. The user can modify the setting by tapping '-' or '+' and can confirm by tapping 'V' or decline by tapping 'X'.

Auto restart menu

Tap the Auto restart icon to enter the Auto Restart menu.

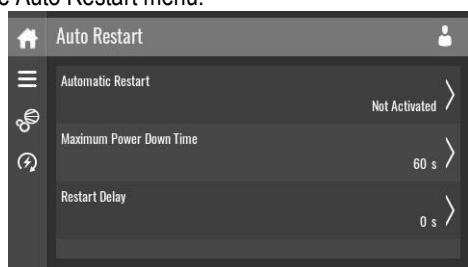

85221D

Through this menu, the automatic restart can be activated. The activation is password protected.

The automatic restart settings can also be changed.

Enter a password

When tapping a password protected item, a selection screen pops up. The user can enter the password by swiping up or down to select the desired number. Once the 4 digits are entered, the user can confirm by tapping 'V' or decline by tapping 'X'.

Modify a setting

When clicking a list item, a selection screen pops up. The user can modify the setting by tapping '-' or '+' and can confirm by tapping 'V' or decline by tapping 'X'.

Controller settings menu

Function

This screen is used to display the following submenus:

- Network Settings
- Localisation
- User Password
- Help
- Information

These submenus can be entered by tapping the icons.

Procedure

To enter the Controller Settings menu screen:

1. Tap the Menu button
2. Tap the Controller Settings icon

Description

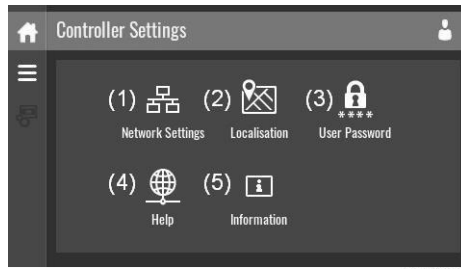

85228D

Reference	Designation
(1)	Network Settings menu
(2)	Localisation menu
(3)	User Password menu
(4)	Help menu
(5)	Information menu

Network settings menu

Tap the Network Settings icon to enter the Network Settings menu.

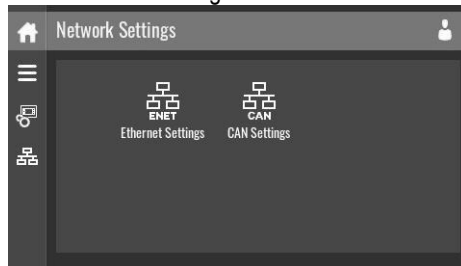

85223D

Ethernet Settings

The list of Ethernet Settings is shown. When ethernet is turned off, the settings can be modified.

CAN Settings

The list of CAN Settings is shown. When CAN is turned off, the settings can be modified.

Modify a setting

When tapping a list item, a selection screen pops up. The user can modify the setting by tapping '-' or '+' and can confirm by tapping 'V' or decline by tapping 'X'.

Change a selection

When tapping a list item, a selection screen pops up. The user can change the selection by swiping up or down and confirm by tapping 'V' or decline by tapping 'X'.

Localization menu

Tap the Localization icon to enter the Localization menu.

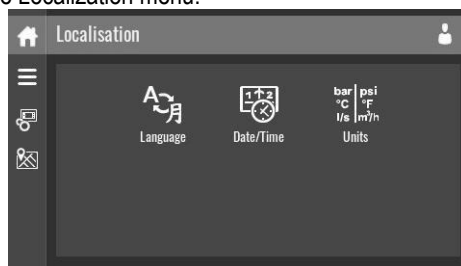

85224D

Language

The language setting of the controller can be modified through this menu. **Date/Time**

The date and time settings of the controller can be modified through this menu.

Units

The units displayed can be modified through this menu.

Modify a setting

When tapping a list item, a selection screen pops up. The user can modify the setting by tapping '-' or '+' and can confirm by tapping 'V' or decline by tapping 'X'.

Change a selection

When tapping a list item, a selection screen pops up. The user can change the selection by swiping up or down and confirm by tapping 'V' or decline by tapping 'X'.

User password menu

Tap the User Password icon to enter the User Password menu.

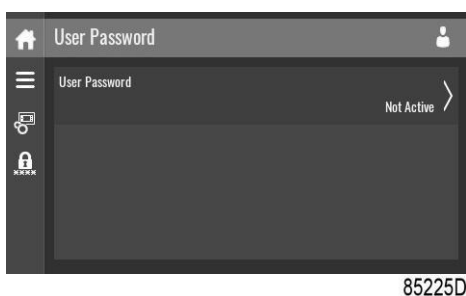

The user password can be activated or deactivated through this menu. Enter and confirm a user password to activate, repeat to deactivate.

Enter a password

When tapping a password protected item, a selection screen pops up. The user can enter the password by swiping up or down to select the desired number. Once the 4 digits are entered, the user can confirm by tapping 'V' or decline by tapping 'X'.

Help menu

Tap the Help icon to enter the Help menu.

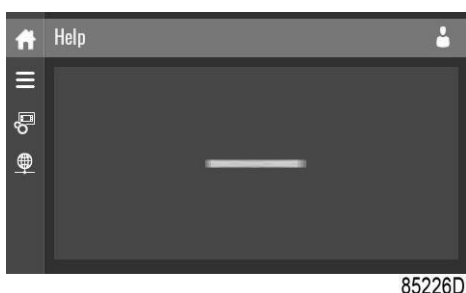

This menu can show a link to the web page of your supplier, a helpdesk phone number or other helpful information.

Information menu

Tap the Information icon to enter the Information menu.

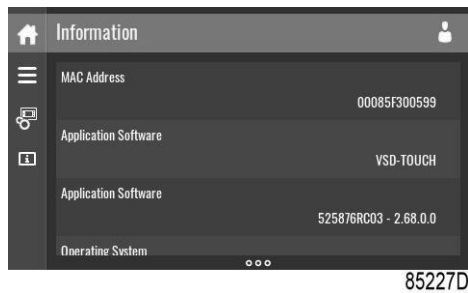

This menu shows information about the controller.

Access level

Function

Through this pop-up screen the access level settings can be viewed or changed.

Procedure

The Access Level screen can be viewed or changed by tapping the Access Level button at the upper right corner of the screen.

Description



Reference	Designation	Function
(1)	User	A basic set of parameters is visualized, no password required.
(2)	Service	A basic set of parameters can be modified, no password required.
(3)	Full	This access level is not accessible to end users.
(4)	Decline	Tap to decline the selected user level.
(5)	Confirm	Tap to confirm the selected user level.

Service access level



Tap the Service access level icon (1) and confirm (2).



The screen information bar (1) now shows the current status of the unit instead of the machine serial number.

The Received Signal Strength Indicator (RSSI) value is now shown in the Internal SmartBox menu.

See Quick access screen.

In the service menu, an extra menu item is now available. See Service menu.

Programmable settings

Parameters

		Minimum setting	Factory setting	Maximum setting
Number of motor starts	starts/day	0	240 (Fix Speed unit)	
Minimum stop time	sec	10	20	30
Power recovery time (ARAVF)	sec	60	60	3600
Restart delay	sec	60	60	1200

Service plan

The built-in service timers will give a Service warning message after their respective preprogrammed time interval has elapsed.

Also see section .

Consult customer center if a timer setting has to be changed. The intervals must not exceed the nominal intervals and must coincide logically. See section Modifying general settings.

Terminology

Term	Explanation
ARAVF	Automatic Restart After Voltage Failure. See section Modifying general settings.
Power recovery time	Is the period within which the voltage must be restored to have an automatic restart. Is accessible if the automatic restart is activated. To activate the automatic restart function, consult Customer Center
Restart delay	This parameter allows to program that not all compressors are restarted at the same time after a power failure (ARAVF active).
Compressor element outlet	The recommended minimum setting is 70 °C (158 °F). For testing the temperature sensor the setting can be decreased to 50 °C (122 °F). Reset the value after testing. The regulator does not accept illogical settings, e.g. if the warning level is programmed at 95 °C (203 °F), the minimum limit for the shutdown level changes to 96 °C (204 °F). The recommended difference between the warning level and shutdown level is 10 °C (18 °F).

Term	Explanation
Delay at shutdown signal	Is the time for which the signal must exist before the compressor is shut down. If it is required to program this setting to another value, consult Atlas Copco.
Oil separator	Use only original oil separators. The recommended maximum pressure drop over the oil separator element is 1 bar (14,5 psi).
Minimum stop time	Once the compressor has automatically stopped, it will remain stopped for the minimum stop time, whatever happens with the net air pressure. Customer center if a setting lower than 20 seconds is required.
Unloading/ Loading pressure	The regulator does not accept inconsistent settings, e.g. if the unloading pressure is programmed at 7.0 bar(e) (101 psi(g)), the maximum limit for the loading pressure changes to 6.9 bar(e) (100 psi(g)). The recommended minimum pressure difference between loading and unloading is 0.6 bar (9 psi(g)).

14.6 Web server

All controllers have a built-in web server that allows direct connection to the company network or to a dedicated PC via a local area network (LAN). This allows to consult certain data and settings via a PC instead of the display of the controller.

Getting started

Make sure you are logged in as administrator.

- Use the internal network card from your computer or a USB to LAN adapter.
- Use a UTP cable (CAT 5e) to connect to the controller (see picture below).



Configuration of the network card

- Go to Network and Sharing Center (1).

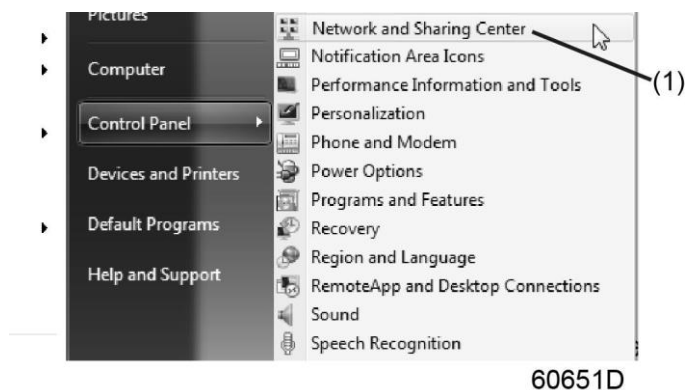

- Click on Change adapter settings (1).

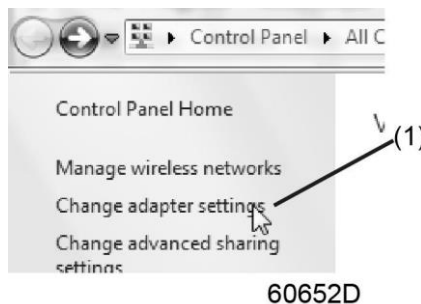

- Select the Local Area Connection, which is connected to the controller.



60653D

- Click with the right button and select Properties (1).

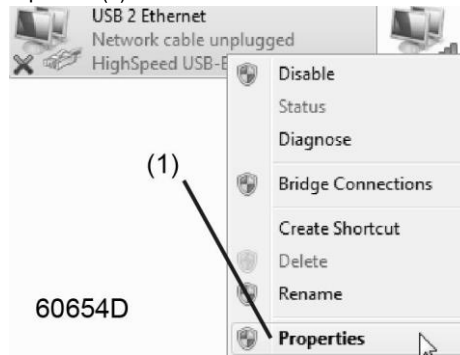

- Use the check box Internet Protocol version +4 (TCP/IPv4) (1) (see picture). To avoid conflicts, uncheck other properties if they are checked. After selecting TCP/IPv4, click on the Properties button (2) to change the settings.

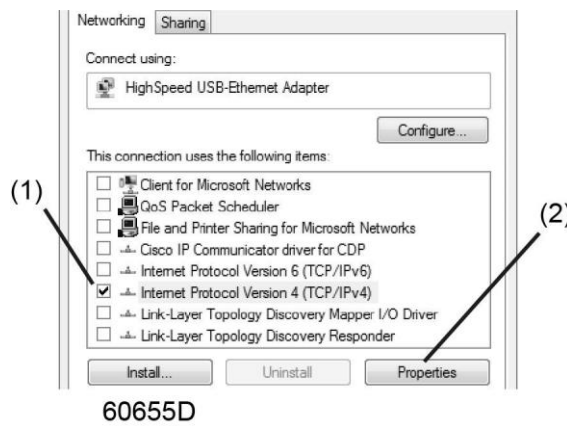

- Use the following settings:
- IP Address 192.168.100.200 (1)
- Subnetmask 255.255.255.0 (2) Click OK (3) and close network connections.

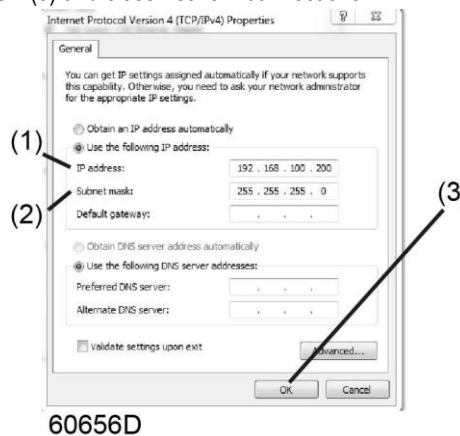

Configure a company network (LAN) connection

- Ask your IT department to generate a fixed IP address in your company's network.
- That IP address will be excluded from the DNS server, so it will be reserved for the controller.
- Also get the correct Gateway and Subnet mask settings. For example:
 - IP = 10.25.43.200
 - Gateway = 10.25.42.250
 - Subnet mask = 255.255.254.0
- Connect the controller to the company's network (LAN) by using a UTP cable (min. CAT 5e).

Adapt the network settings in the controller:

- Go to Main Menu
 - Go to Settings (1)
 - Go to Network (1)
 - Go to Ethernet (1)
 - Switch Off (1) the Ethernet communication to allow editing the settings
 - Adapt IP Address (1)
 - Adapt Gateway IP (2)
 - Adapt Subnet Mask (3)
 - Switch On (4) the Ethernet communication

Wait a few minutes so the LAN network can connect to the controller

Configuration of the web server

The internal web server is designed and tested for Microsoft® Internet Explorer.

Also "Opera", "Mozilla Firefox", "Safari" and "Chrome" should work.

Viewing the controller data



All screen shots are indicative. The number of displayed fields depends on the selected options.

- Open your browser and type the IP address of the controller you want to view in your browser (in this example <http://192.168.100.100>). The interface opens:

The screenshot shows a web interface for a compressor controller. At the top right, there is a language dropdown menu set to 'English'. Below this, there are four checked checkboxes: 'Analog Inputs', 'Counters', 'Digital Inputs', and 'Digital Outputs'. Under 'Special Protections', 'Service Plan' is also checked. The main content area is divided into several sections:

- Analog Inputs:** A table with two columns: 'Element' and 'Value'. It shows 'Element Outlet' at 80.40 °C and 'Compressor Outlet' at 6.40 bar.
- Counters:** A table with two columns: 'Counter' and 'Value'. It shows 'Running Hours' (140 hrs), 'Loaded Hours' (140 hrs), 'Motor Starts' (4), 'Load Relay' (5), and 'Module Hours' (492 hrs).
- Info:** A section with a 'Machine Status' icon. It contains a table of 'Digital Inputs' with columns 'Input' and 'Value'. Values include 'Emergency Stop' (Closed), 'Overload Motor/Fan Motor' (Closed), 'Remote Start/Stop' (Open), 'Remote Load/Unload' (Open), 'Remote Pressure Sensing' (Open), and 'Pressure Setting Selection' (Pressure Band 1).
- Digital Outputs:** A table with columns 'Output' and 'Value'. Values include 'Line Contactor' (Closed), 'Star Contactor' (Open), 'Delta Contactor' (Closed), 'Load/Unload' (Closed), 'General Shutdown' (Closed), 'Automatic Operation' (Closed), and 'General Warning' (Closed).
- Special Protections:** A section with a 'No Valid Pressure Control' indicator. It contains a 'Service Plan' table with columns 'Plan' and 'Level'. It shows 'Running Hours' for plans A, B, C, and D with corresponding values and progress bars.

81520D

Screen shot (example!)

Navigation and options

- The banner shows the unit type and the language selector. In this example, three languages are available on the controller.



81521D

- On the left side of the interface, you can find the navigation menu.
If a license for ECONTROL is foreseen, the menu contains 3 buttons.
- Machine: shows all generator settings.
- ECO: shows the status (if a license is provided).
- Preferences: allows to change temperature and pressure unit.

Unit settings

All unit settings can be displayed or hidden. Put a check mark in front of each point of interest and it will be displayed. Only the machine status is fixed and can not be removed from the main screen.

Analog inputs

Lists all current analog input values. The measurement units can be changed in the preference button from the navigation menu.

Counters

Lists all current counter values from controller and unit.

Info status

Machine status is always shown on the web interface.

Digital inputs

Lists all digital inputs and their status.

Digital outputs

Lists all digital outputs and their status.

Special protections

Lists all special protections of the unit.

Service plan

Displays all levels of the service plan and their status. This screen shot underneath only shows the running hours. It is also possible to show the current status of the service interval.

15.0 ORDINARY MAINTENANCE TO BE DONE BY THE USER

BEFORE PERFORMING ANY MAINTENANCE, IT IS MANDATORY TO STOP THE MACHINE AND DISCONNECT IT FROM THE POWER MAINS AND FROM THE COMPRESSED AIR DISTRIBUTION NETWORK.

The maintenance jobs described in this chapter may be carried out by the user.

The more complex maintenance jobs which require professionally skilled personnel are listed in the chapter on **GENERAL ROUTINE MAINTENANCE**. (See Chap. 21.0)

15.1 GENERAL INFORMATION**15.2 MAINTENANCE PROGRAMME****■ OPERATIONS THAT MAY BE CARRIED OUT BY THE USER****■ ■ OPERATIONS THAT REQUIRE SKILLED PERSONNEL ; THESE OPERATIONS ARE ILLUSTRATED IN PART B OF THIS MANUAL.**

These maintenance intervals are recommended for work environments that are not dusty and are well ventilated. For particularly dusty environments, double the frequency of controls.

Every Day (after use)	<ul style="list-style-type: none"> ■ Check automatic condensation drain (unit with dryer)
Every 50 working hours	<ul style="list-style-type: none"> ■ Drain condensate from the oil tank ■ Check the oil level ■ Clean the filter of the automatic condensate drain (unit with dryer) ■ Clean the filtering panel Only VSD ■ Clean the filters of electrical cabinet door.
Every 500 hours	<ul style="list-style-type: none"> ■ Tighten the screws fixing the electric cables (at first 500 hrs) ■ Clean the air inlet filter ■ Clean the condenser heat exchanger (unit with dryer) ■ Clean the inlet filtration panels
Every 2000 hours (or at least every year)	<ul style="list-style-type: none"> ■ Replace the inlet air filter ■ ■ Replace the oil ■ ■ Replace the oil filter ■ ■ Retighten all power cable connections ■ ■ Safety temperature test ■ Change the filter mesh of dryer condensate drain (unit with dryer)
Every 4000 hours (or at least every 2 years)	<ul style="list-style-type: none"> ■ ■ Motor bearings lubrication ■ ■ Clean the finned surface of the air-oil cooler ■ ■ Replace the oil separator filter ■ ■ Service kit for dryer condensate drain (unit with dryer) ■ Change the filter panel ■ Replace the line after filter (change the filter cartridge at least once a year if fitted) Only VSD ■ Replace the filters of electrical cabinet door
Every 8000 hours (or at least every 3 years)	<ul style="list-style-type: none"> ■ ■ Intake service kit ■ ■ Check status of oil return valve and oil pipes ■ ■ Service kit for minimum pressure valve and thermostatic valve ■ ■ Service kit for non-return valve
Every 20000 hours	<ul style="list-style-type: none"> ■ ■ Air-end overhaul kit ■ ■ Service kit Motor (bearings)

15.3 DRAINING CONDENSATE FROM THE OIL TANK

If the compressor work cycle contemplates long pauses during which the machine cools down, a certain amount of condensate will gather in the oil tank. This happens, for example, when stopping overnight or at weekends.

The condensate must be drained off every 50 hours or every week. This operation may be performed only when the machine is cold, that is when it has been switched off for at least 8 hours.



BEFORE DRAINING THE CONDENSATE, IT IS MANDATORY TO STOP THE MACHINE AND DISCONNECT IT FROM THE POWER MAINS.

Proceed as follows:

- Switch off the machine with pushbutton Ref. 1 Fig. 16: in this way the machine stops after idle time running.
- Disconnect the power supply by means of the disconnector switch, Ref. 3 Fig. 16 screw-compressor and for the dryer if fitted.

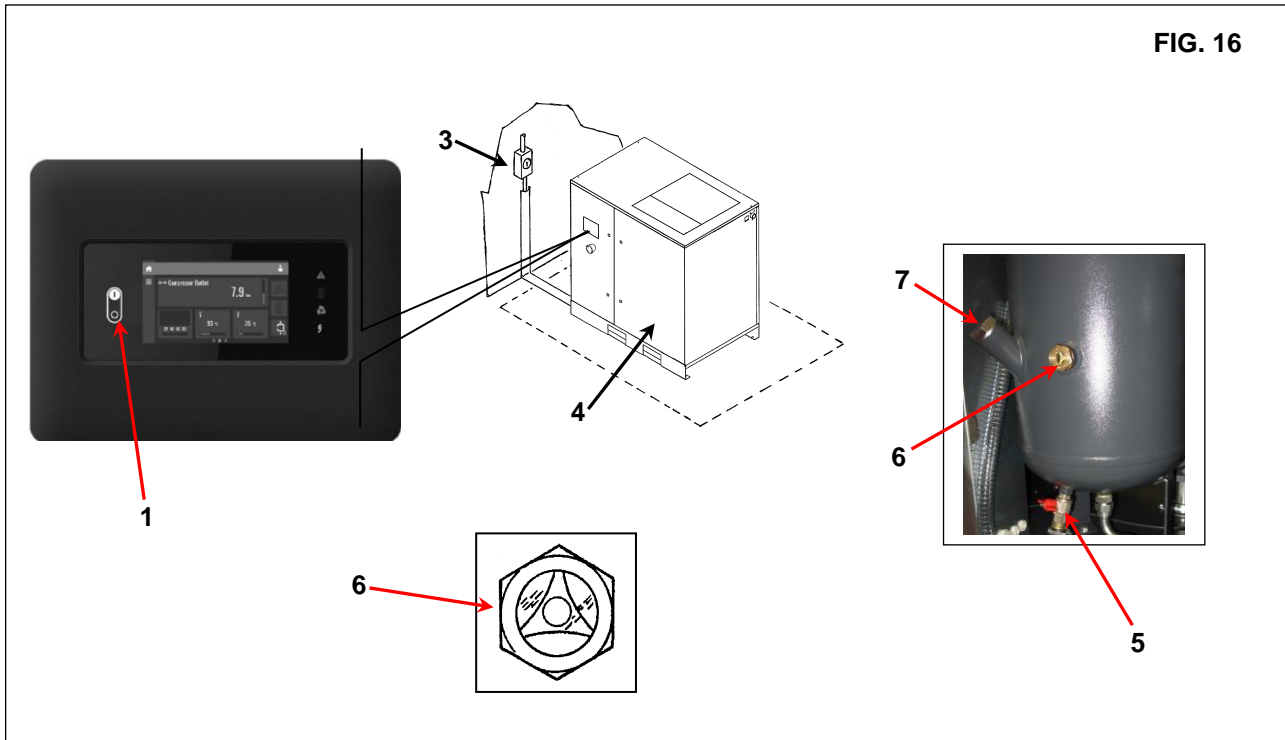

- Wait for the machine to cool down.
- Remove the panels Ref. 4 Fig. 16 with the key provided.
- SLOWLY turn on the tap Ref. 5 Fig. 16 and let the condensate flow out.
- When the first traces of oil appear, turn off the tap.



CONDENSATE MUST BE DISPOSED OF IN CONFORMITY WITH THE LOCAL REGULATIONS IN FORCE.

- Check the oil level on the indicator Ref. 6 Fig. 16.
- If the oil level is under the minimum, top up as described at point 15.4.

15.4 CHECK OIL LEVEL AND TOP UP

- Switch off the machine with push button Ref. 1 Fig. 16: in this way the machine will not stop instantly after idle time running.
- Disconnect the power supply by means of the disconnector switch, Ref. 3 Fig. 16 screw-compressor and for the dryer if fitted.
- Open the front panel Ref. 4 Fig. 16 with the special key.
- Wait approximately 3/4 minutes for the oil level to settle foam in the collector to abate.
- Check immediately the oil level on the indicator Ref. 6 Fig. 16.
- If the oil level is under the minimum Fig. 16B, top up.



USE OIL OF THE SAME TYPE AS THAT ALREADY IN THE MACHINE; DO NOT MIX DIFFERENT TYPES OF OIL.

BEFORE CARRYING OUT ANY OPERATION ON THE MACHINE, ENSURE THAT THE ELECTRIC POWER SUPPLY HAS BEEN DISCONNECTED.

- Slowly open the oil plug Ref. 7 Fig. 16.
- Top up to maximum level Ref. 6 Fig. 16, with oil of the same type in the compressor.
- Turn off the cap of the oil tank Ref. 7 Fig. 16.
- Close the panel Ref. 4 Fig. 16.

OIL LEVEL CHECK**Running unit:**

- Foam level is in the center of sight glass.

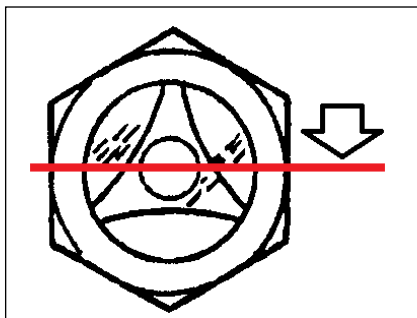

FIG. 16A

Machine just stopped (3/4 minutes):

- When foam disappears, the oil level must be visible on the sight glass (under the max. level).

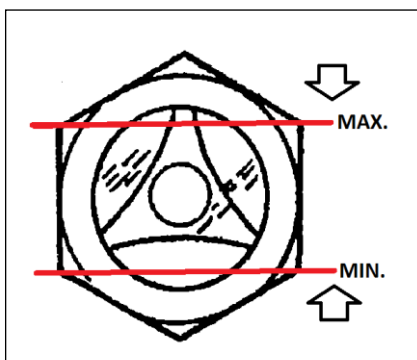

FIG. 16B

ATTENZIONE:

- Do not check level if machine is standing for more than 10 minutes.
- Do not overfill (not higher than the max. level).



BEFORE PERFORMING ANY MAINTENANCE, IT IS MANDATORY TO STOP THE MACHINE AND DISCONNECT IT FROM THE POWER MAINS AND FROM THE COMPRESSED AIR DISTRIBUTION NETWORK.

15.5 CLEANING FILTERS OF ELECTRIC CABINET DOOR (ONLY VSD)

- Switch off the machine with pushbutton Ref. 1 Fig. 16: in this way the machine stops after idle time running.
- Disconnect the power supply by means of the disconnecter switch, Ref. 3 Fig. 16 for screw-compressor and the dryer if fitted.
- Remove the filters covers from cabinet door Ref. 1 Fig. 17.
- Clean the filter pads using compressed air or water. **Do not use solvents.**
- Once operation is complete, reassemble the filter covers Ref. 1 Fig. 17.

EVERY 50 WORKING HOURS, CLEANING THE FILTERS ELECTRICAL PANEL.

FIG. 17

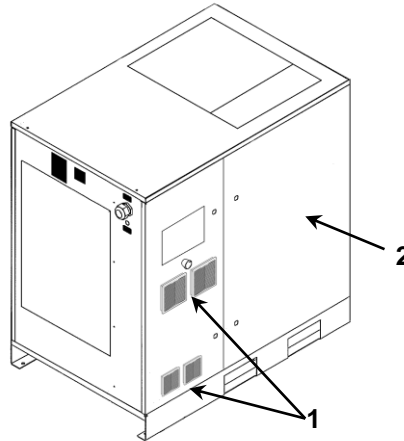

- CLEANING THE INLET PANEL FILTER

- Switch off the machine with pushbutton Ref. 1 Fig. 16: in this way the machine stops after idle time running.
- Disconnect the power supply by means of the disconnecter switch, Ref. 3 Fig. 16 for screw-compressor and for the dryer if fitted.
- Remove the filters covers from cabinet door Ref. 1 Fig. 18.
- Clean the filters pads covers using compressed air or water. **Do not use solvents.**
- Once operation is complete, reassemble the filter covers Ref. 1 Fig. 18.

FIG. 18

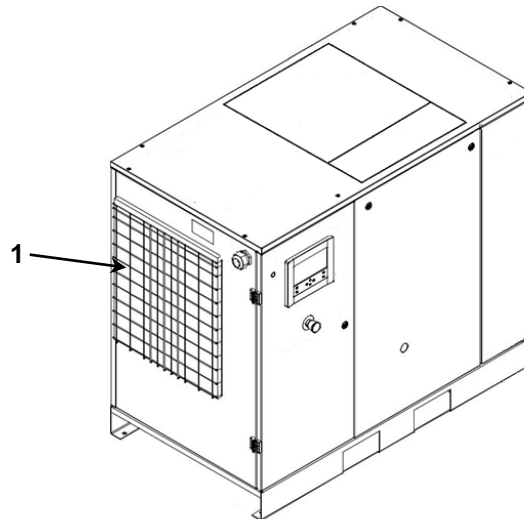



BEFORE PERFORMING ANY MAINTENANCE, IT IS MANDATORY TO STOP THE MACHINE AND DISCONNECT IT FROM THE POWER MAINS AND FROM THE COMPRESSED AIR DISTRIBUTION NETWORK.

15.6 CLEANING THE AIR INLET FILTER OR REPLACING THE FILTER

- Switch off the machine with pushbutton Ref. 1 Fig. 16: in this way the compressor will not stop instantly.
- Disconnect the power supply by means of the disconnecter switch, Ref. 3 Fig. 16 for screw-compressor and for the dryer if fitted.



HOT PARTS INSIDE

- Remove the panel Ref. 2 Fig. 17.
- Remove the cover Ref. 7 Fig. 19.
- Remove the filter Ref. 8 Fig. 19.



AVOID DROPPING FOREIGN BODIES INTO THE INLET DUCT.

- Clean the filter with a jet of air, working from inside to outside, **DO NOT USE WATER OR SOLVENTS**. Alternatively, fit a new filter.
- Clean the disk on which the filter rests with a clean cloth.
- Fit the filter and the cover.
- If necessary, dispose of the old filter in conformity with the local regulations in force.
- Close the panel Ref. 2 Fig. 17.

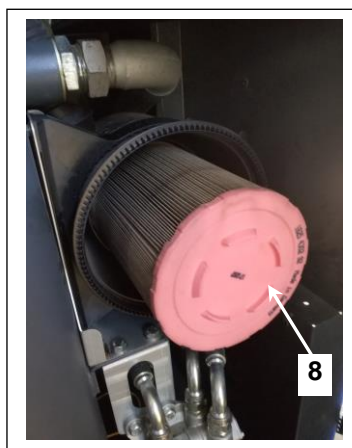
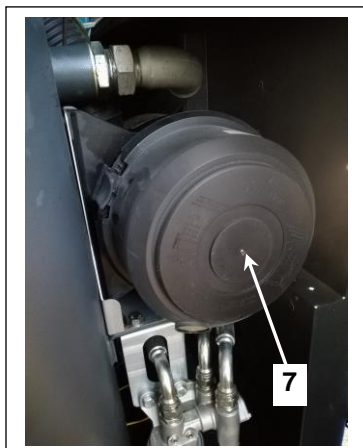

FIG. 19

15.7 CHECKING THE AUTOMATIC AND MANUAL CONDENSATE DRAIN (FOR DRYER IF FITTED)



BEFORE PERFORMING ANY MAINTENANCE, IT IS MANDATORY TO STOP THE MACHINE AND DISCONNECT IT FROM THE POWER MAINS AND FROM THE COMPRESSED AIR DISTRIBUTION NETWORK.

The automatic condensation drain must be checked (Rif. 1 every 500 hours) Fig. 20.

Proceed as follows:

- Press the "TEST" button, Ref. 1 Fig. 20, for a few seconds to check if the condensation is correctly emptied from the drainage pipe

FIG. 20

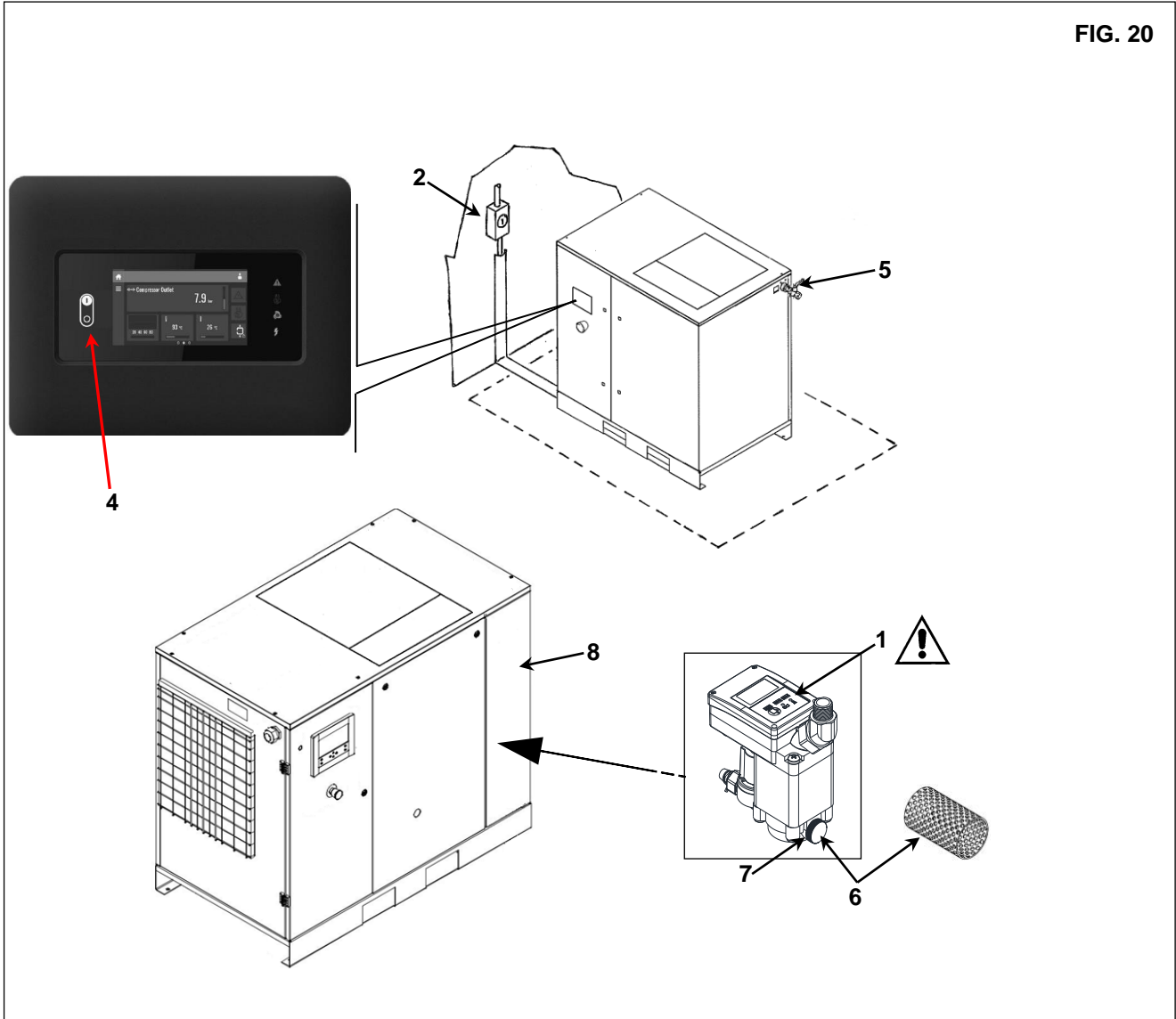

15.8 CLEAN THE DRAIN MESH (ONLY FOR UNITS EQUIPPED WITH REFRIGERANT DRYER)

Proceed as follows:

- Close the ball valve at machine at the air outlet Ref. 5 Ref. 20
- Remove the panel Ref. 8 Fig. 20
- Depressurise the dryer by pressing the "TEST" button on drain (for about 10-20 seconds) Ref. 1 Fig.20
- Switch off the machine with push button Ref. 4 Fig. 20: in this way the machine stops after idle time running.
- Disconnect the power supply by means of the disconnecter switch, Ref. 2 Fig. 20 for screw-compressor and for the dryer.
- Remove the threaded plug Ref. 6 Fig. 20
- Remove the filter Ref. 7 Fig. 20 (filter mesh)
- Clean the filter mesh using compressed air.
- Install the filter, fix the plug.
- Install the panel Ref. 8 Fig. 20

15.9 CLEANING CONDENSER HEAT EXCHANGER (ON THE DRYER IF FITTED)



BEFORE PERFORMING ANY MAINTENANCE, IT IS MANDATORY TO STOP THE MACHINE AND DISCONNECT IT FROM THE POWER MAINS AND FROM THE COMPRESSED AIR DISTRIBUTION NETWORK.

The condenser must be cleaned every month.

Proceed as follows:

- Switch off the machine with push button Ref. 1 Fig. 21: in this way the compressor will not stop instantly.
- Disconnect the power supply by means of the disconnecter switch, Ref. 2 Fig. 21 for screw-compressor and for the dryer.



HOT PARTS INSIDE THE DRYER

- Remove the filter panel Rif. 4 Fig. 21
- Clean the condenser fins with compressed air (See Fig A). **DO NOT USE WATER OR SOLVENTS.**
- Re-assemble the back-panel Rif. 4 Fig. 21

FIG. 21

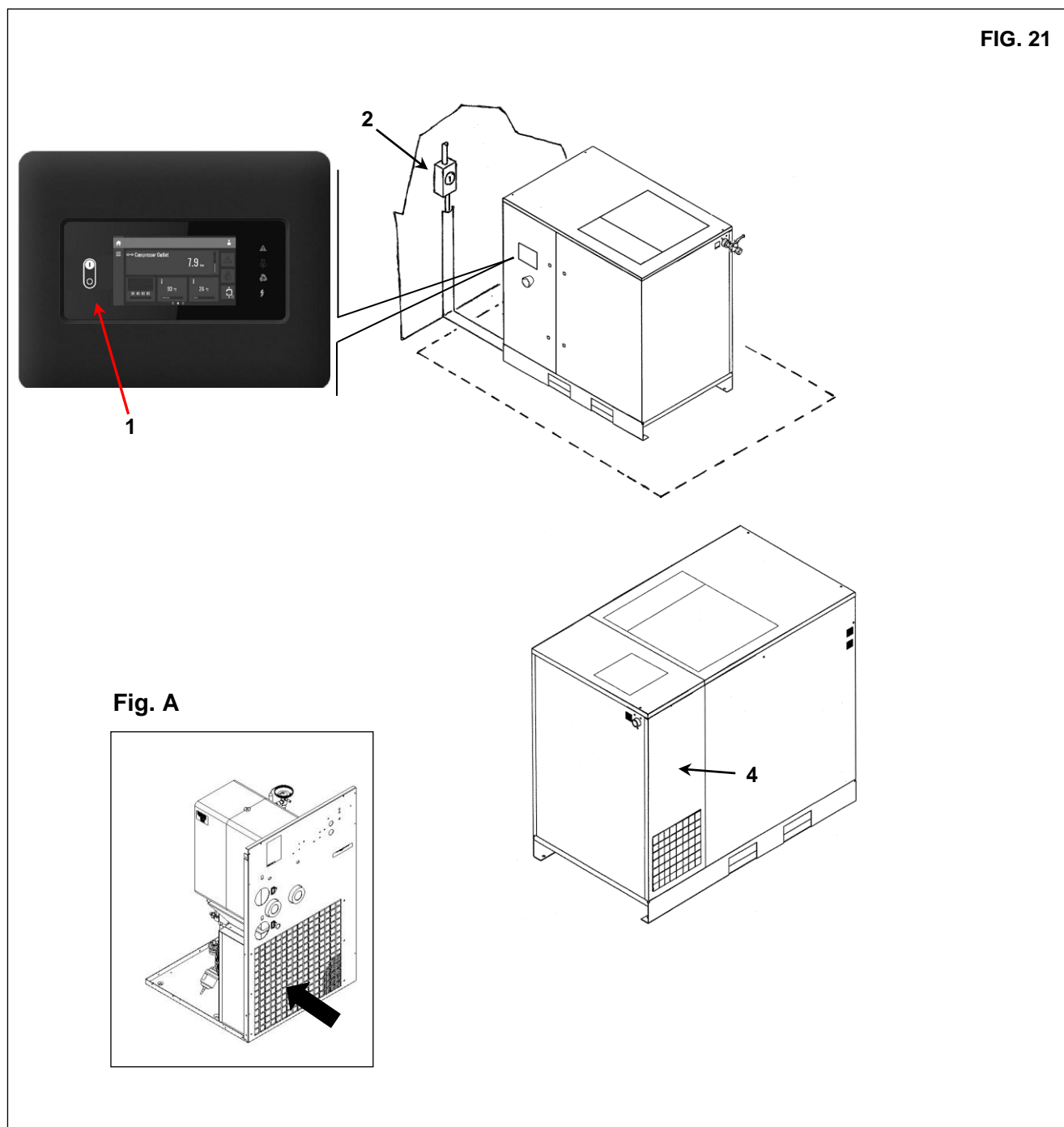

16.0 PERIODS OF INACTIVITY

If the machine remains inactive for a long period:

- Close the ball valve Ref. 1 Fig. 22.
- Remove the panel Ref. 8 Fig. 22
- Depressurise the dryer by pressing the "TEST" condensate drain button (for about 10-20 seconds) Ref. 2 Fig.22
- Switch off the machine with press Ref. 3 Fig. 22: in this way the machine stops after idle time running.
- Disconnect the power supply by means of the disconnecter switch, Ref. 4 Fig. 22 for screw-compressor and for the dryer if fitted.
- Assemble the panel Ref. 8 Fig. 22.

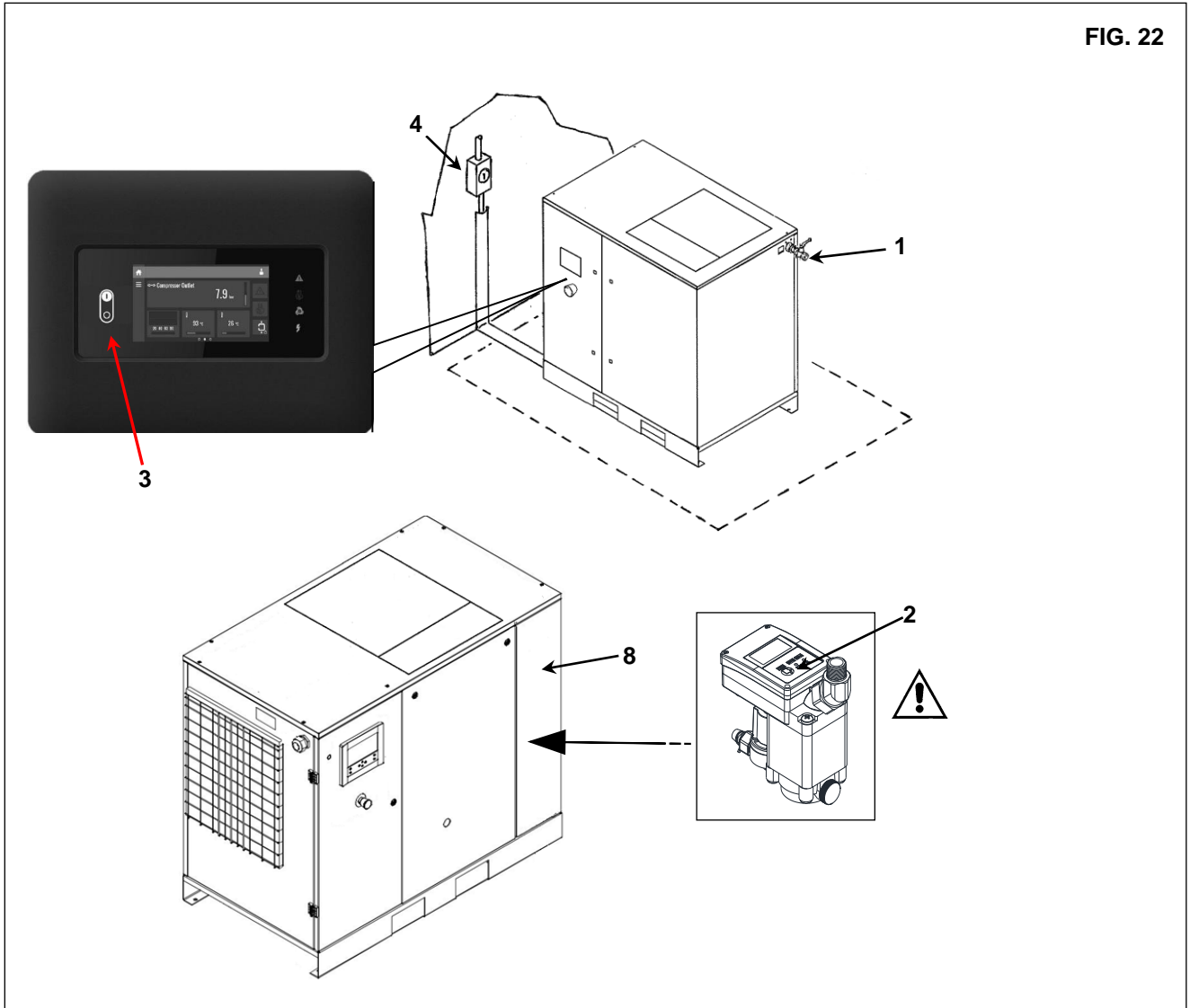

During periods of inactivity the unit needs to be protected against atmospheric agents, dust and humidity which could damage the motor and the electrical system.

To restart the machine after periods of inactivity, consult the manufacturer.

17.0 SCRAPPING THE UNIT

If the machine needs to be scrapped, it must be dismantled into parts of the same material, to be disposed of according to the local regulations in force.



ALWAYS RESPECT THE REGULATIONS IN FORCE FOR DISPOSING OF OLD OIL AND OTHER POLLUTING MATERIALS SUCH AS SOUND-PROFING, INSULATING FOAM, ETC.

18.0 LIST OF SPARE PARTS FOR ROUTINE MAINTENANCE

Réf	DESCRIPTION	Q.ty	Code	HP 40 / kW 30				HP 50 / kW 37				HP 60 / kW 45			
				7,5 bar	8,5 bar	10 bar	13 bar	7,5 bar	8,5 bar	10 bar	13 bar	7,5 bar	8,5 bar	10 bar	13 bar
2	Oil filter	1	2204 2276 01	■	■	■	■	■	■	■	■	■	■	■	■
3	Air filter	1	1630 4302 94	■	■	■	■	■	■	■	■	■	■	■	■
4	Separator cartridge	1	2204 2236 35	■	■	■	■	■	■	■	■	■	■	■	■
5	Gaskets separator cartridge	2	2204 1197 00	■	■	■	■	■	■	■	■	■	■	■	■
6	Pre filtration	1	2204 1203 03	■	■	■	■	■	■	■	■	■	■	■	■
	Grease tube (pack of 8 grams)	5	1630 2023 00	■	■	■	■	■	■	■	■	■	■	■	■

Réf	DESCRIPTION	Q.ty	Code	HP 40 (VSD) kW 30 (VSD)		HP 50 (VSD) kW 37(VSD)		HP 60 (VSD) kW 45 (VSD)	
				10 bar	12,5 bar	10 bar	12,5 bar	10 bar	12,5 bar
1	Filters electrical panel	2	1630 0589 00	■	■	■	■	■	■
1	Filters electrical panel	2	1630 0589 05	■	■	■	■	■	■
2	Oil filter	1	2204 1331 50	■	■	■	■	■	■
3	Air filter	1	1630 4302 94	■	■	■	■	■	■
4	Separator cartridge	1	2204 2236 35	■	■	■	■	■	■
5	Gaskets separator cartridge	2	2204 1197 00	■	■	■	■	■	■
6	Pre filtration	1	2204 1203 03	■	■	■	■	■	■
	Grease tube (pack of 8 grams)	5	1630 2023 00	■	■	■	■	■	■

FIG. 23

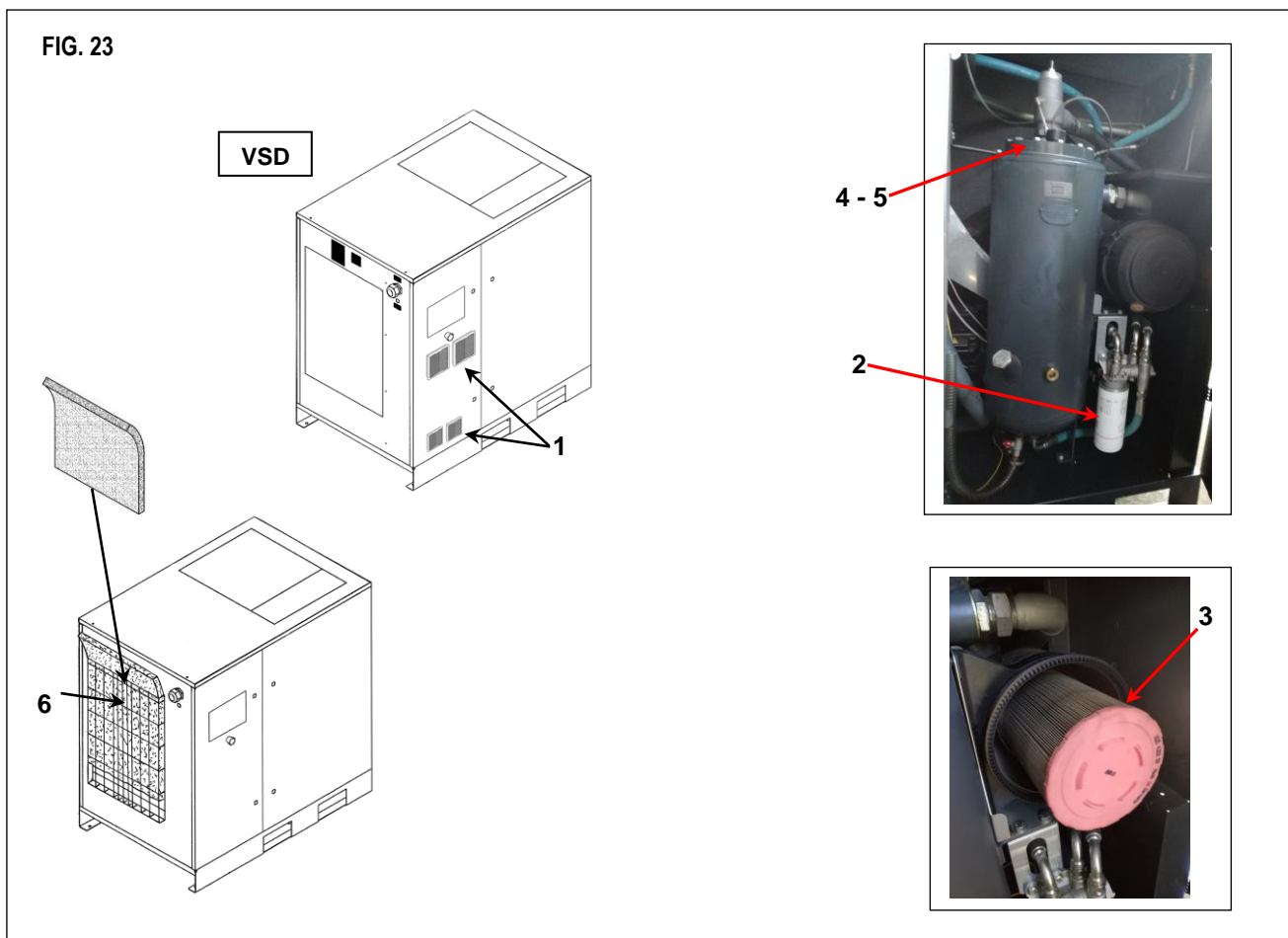

19.0 TROUBLE-SHOOTING AND EMERGENCY REMEDIES

N.B. OPERATIONS MARKED ■ ■ MUST BE PERFORMED BY PROFESSIONALLY SKILLED PERSONNEL APPROVED THE MANUFACTURER.



ALL WORK MUST BE PERFORMED BY PROFESSIONALLY SKILLED PERSONNEL. BEFORE CARRYING OUT ANY MAINTENANCE JOBS IT IS MANDATORY TO STOP THE MACHINE AND DISCONNECT IT FROM THE POWER MAINS.

19.1 TROUBLE-SHOOTING AND EMERGENCY REMEDIES FOR SCREW COMPRESSOR (Standard controller for fixed speed compressor and VSD compressors)

FAULT FOUND	POSSIBLE CAUSES	OBSERVATIONS
1) The machine does not start	1A - no power 1B - the transformer protection device has tripped	- check the power supply line, Chapter 12.2 - replace fuses
2) The machine does not start the pilot lamp (Ref. 8 Fig. 15 – 16) is flashes. The pictograph appears intermittently (Ref. 7 Tab. B)	2A - Phases incorrect 2B - the main motor protection device has tripped 2C – Temperature switch on element outlet has tripped	- Verify phase sequence - to check possible motor failure -environment temperature too high; improve ventilation in the compressor room, Chapter 9.2 ■ ■ - cooling radiator is dirty, clean the radiator - oil level too low; top up the oil tank
3) The machine does not start the pilot lamp (Ref. 8 Fig. 15 – 16) is flashes. The pictograph appears intermittently (Ref. 5 Tab. B)	3A - The oil high temperature protection has tripped	- environment temperature too high; improve ventilation in the compressor room, Chapter 9.2 ■ ■ - cooling radiator is dirty, clean the radiator - oil level too low; top up the oil tank
4) The compressor does not reach working pressure	4A - the compressed air consumption is too high 4B - the discharge electrovalve remains closed.	■ ■ - check the electric system
5) Excess oil consumption	5A - deteriorated oil separating filter oil level is too high	■ ■ - change the oil separating filter, Chapter 23

19.2 - TROUBLE-SHOOTING AND EMERGENCY REMEDIES FOR SCREW COMPRESSOR (Graphic controller for fixed speed compressor and VSD compressor.)

FAULT FOUND	POSSIBLE CAUSES	OBSERVATIONS
1) The machine does not start	1A - no power 1B - the transformer protection device has tripped	- check the power supply line, Chapter 12.2 - replace fuses
2) The machine does not start the pilot lamp (Ref. 5 Fig.16) is flashes. The pictograph appears intermittently (Status icons Shutdown)	2A - Phases incorrect 2B - the main motor protection device has tripped 2C – Temperature switch on element outlet has tripped	- Verify phases sequence - to check possible motor failure -environment temperature too high; improve ventilation in the compressor room, Chapter 9.2 ■ ■ - cooling radiator is dirty, clean the radiator - oil level too low; top up the oil tank
3) The machine does not start the pilot lamp (Ref. 5 Fig.16) is flashes. The pictograph appears intermittently (Status icons Shutdown)	3A - The oil high temperature protection has tripped	- environment temperature too high; improve ventilation in the compressor room, Chapter 9.2 ■ ■ - cooling radiator is dirty, clean the radiator - oil level too low; top up the oil tank
4) The compressor does not reach working pressure	4A - the compressed air consumption is too high 4B - the discharge electrovalve remains closed.	■ ■ - check the electric system
5) Excess oil consumption	5A - deteriorated oil separating filter oil level is too high	■ ■ - change the oil separating filter, Chapter 23

19.3 TROUBLE-SHOOTING FOR REFRIGERANT DRYER



ALL WORK MUST BE PERFORMED BY PROFESSIONALLY SKILLED PERSONNEL. BEFORE CARRYING OUT ANY MAINTENANCE JOBS IT IS MANDATORY TO STOP THE MACHINE AND DISCONNECT IT FROM THE POWER MAINS.

N.B. OPERATIONS MARKED ■ ■ MUST BE PERFORMED BY PROFESSIONALLY SKILLED PERSONNEL APPROVED THE MANUFACTURER

FAULT FOUND	POSSIBLE CAUSES	OBSERVATIONS
1) No compressed air passes through the dryer outlet	1A) The pipes are frozen inside	<ul style="list-style-type: none"> ■ ■ -Hot gas by-pass the bypass valve is broken or out-of-calibration -The room temperature is too low and the evaporators piping are obstructed with ice
2) Presence of condensate in the pipings.	2A) The condensate separator does not work correctly 2B) The dryer is working outside its rating 2C) The dryer is working under bad excessive conditions.	<ul style="list-style-type: none"> ■ ■ -Check the solenoid exhaust valve ■ ■ -Check the drainage timer -Check the flow rate of treated air -Check the room temperature -Check the air temperature at the drier inlet. -Clean the condenser. ■ ■ -Check dryer fan operation.
3) The compressor head is very hot	Make reference to 2B Make reference to 2C 3A) The cooling circuit is not working with the right gas charge	<ul style="list-style-type: none"> ■ ■ -Check if there are leaks of refrigerating gas. ■ ■ - Charge it again.
4) Motor cuts out on overload	Make reference to 2B Make reference to 2C Make reference to 3A	
5) The motor hums and does not start.	The line voltage is too low. The starting system of the motor is defective.	<ul style="list-style-type: none"> -Contact the electric power company ■ ■ - Check the running capacitor
6) The machine has stopped and does not restart even after a few minutes.	The overload protection with has intervened: make reference to 2B-2C-3A. The motor has burnt out.	
7) The compressor is very noisy.	Troubles with the internal mechanical parts or with the valves	

PART "B"



THIS PART "B" OF THE INSTRUCTIONS MANUAL IS RESERVED FOR PROFESSIONALLY SKILLED PERSONNEL APPROVED THE MANUFACTURER

WARNING: CAPACITORS INSIDE INVERTER MAY REMAIN CHARGED FOR 15 MINUTES AFTER THE UNIT HAS BEEN DISCONNECTED FROM MAIN SUPPLY.

WAIT AT LEAST 15 MINUTES AFTER POWER SUPPLY HAS BEEN REMOVED BEFORE PERFORM SERVICE OR REPAIR TO AVOID DEATH OR SERIOUS INJURY.

20.0 STARTING UP



BEFORE PERFORMING ANY OPERATION ON THE MACHINE, ENSURE THAT THE ELECTRIC POWER SUPPLY HAS BEEN DISCONNECTED.

20.1 PREPARE FOR START

20.2 Preliminary checks

When delivered, the machine is filled with oil;

If unit is installed more than 3 months after factory inspection: lubricate the screw element before start.

According to below procedure:

- Remove the pipe Ref. 2 Fig. 24 by loosening the clamp screw.
- Pour a little oil into the inlet valve.
- Reassemble the pipe Ref. 2 Fig. 24

If more than 6 months elapsed between factory inspection and installation, please contact the service centre.



FIG. 24

20.3 CHECK THE DIRECTION OF ROTATION

- Check that all fixed guards are in their correct position.
- Connect the control board to the power supply with the disconnecter switch of the line Rif. 1 Fig. 25.
- Check the direction of rotation (following the arrow on the coupling housing Rif. 3 Fig. 25). By pressing the "Start" button Rif. 2 Fig. 25, followed immediately by the emergency stop Rif. 4 Fig. 25. If it does not spin in the right direction reverse two mains cables. When it rotates in the correct direction, the oil level Rif. 5 Fig. 25 should drop after 4 or 5 seconds of operation. It is very important to remember to check the direction of rotation of the fan (shown by an arrow on the fan Rif. 6 Fig. 25).



ALL MAINTENANCE ON ELECTRICAL PARTS, MUST BE PERFORMED BY PROFESSIONALLY SKILLED PERSONNEL.

- IT IS ADVISABLE TO NOT TAMPER WITH ELECTRIC CABINET

IF ALL THE INSTRUCTIONS FOUND IN THIS MANUAL HAVE BEEN OBSERVED THE MACHINE CAN BE STARTED.



ATTENTION: wait at least 20 seconds before starting the machine after a switch off

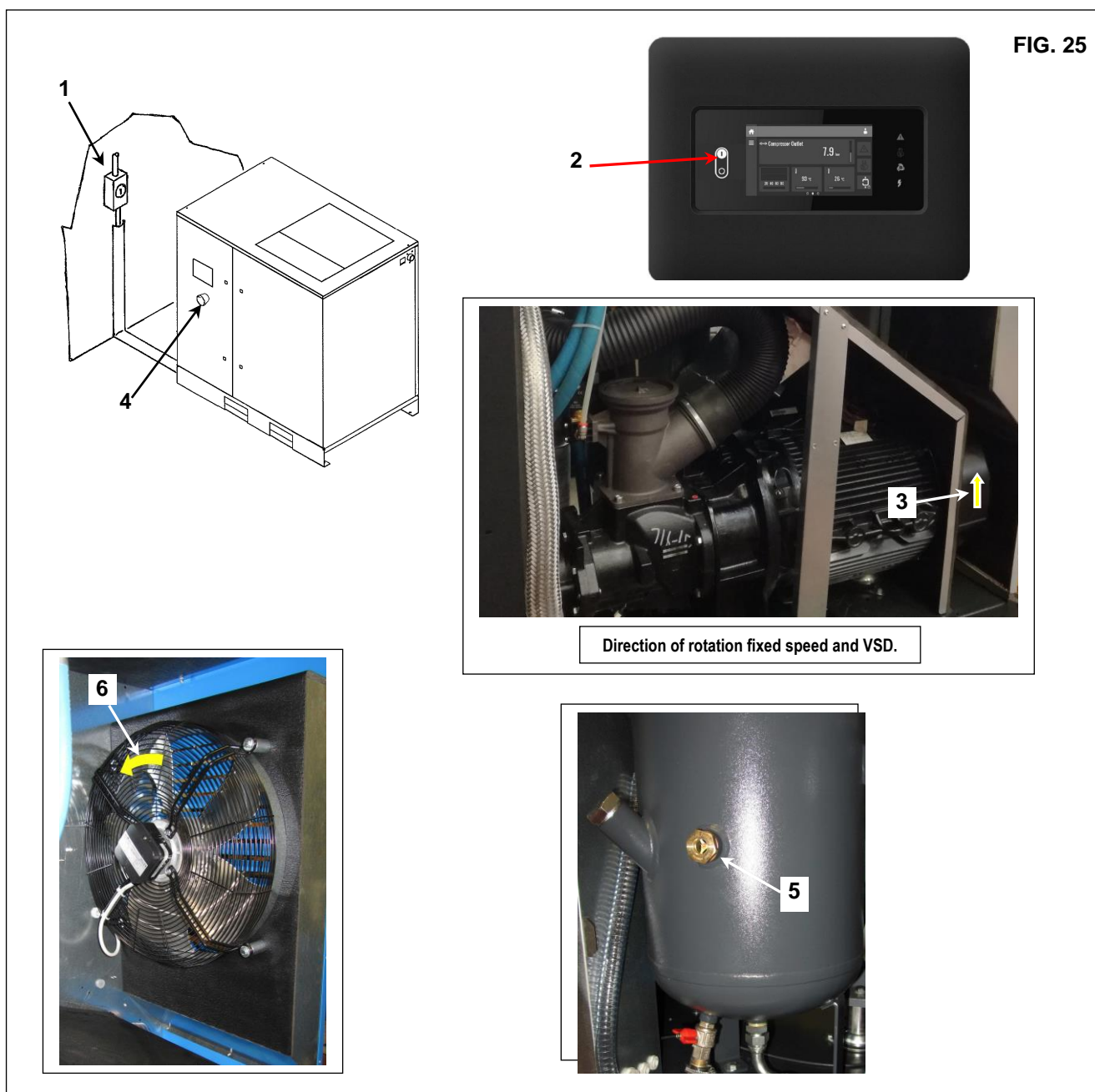

FIG. 25

Direction of rotation fixed speed and VSD.

21.0 GENERAL ORDINARY MAINTENANCE REQUIRES TRAINED PERSONNEL



BEFORE CARRYING OUT ANY MAINTENANCE IT IS MANDATORY TO STOP THE MACHINE AND DISCONNECT IT FROM THE POWER MAINS.

MAINTENANCE SCHEDULE

These maintenance intervals are recommended for work environments that are not dusty and are well ventilated. For particularly dusty environments, double the frequency of controls.

Every Day (after use)	<ul style="list-style-type: none"> ■ Check automatic condensation drain (unit with dryer)
Every 50 working hours	<ul style="list-style-type: none"> ■ Drain condensate from the oil tank ■ Check the oil level ■ Clean the filter of the automatic condensate drain (unit with dryer) ■ Clean the filtering panel Only VSD ■ Clean the filters of electrical cabinet door.
Every 500 hours	<ul style="list-style-type: none"> ■ Replace oil (at first 500 hrs) ■ Replace oil filter (at first 500 hrs) ■ Tighten the screws fixing the electric cables (at first 500 hrs) ■ Clean the air inlet filter ■ Clean the condenser heat exchanger (unit with dryer) ■ Clean the inlet filtration panels
Every 2000 hours (or at least every year)	<ul style="list-style-type: none"> ■ Replace the inlet air filter ■ ■ Replace the oil ■ ■ Replace the oil filter ■ ■ Retighten all power cable connections ■ ■ Safety temperature test ■ Change the filter mesh of dryer condensate drain (unit with dryer)
Every 4000 hours (or at least every 2 years)	<ul style="list-style-type: none"> ■ ■ Motor bearings lubrication ■ ■ Clean the finned surface of the air-oil cooler ■ ■ Replace the oil separator filter ■ ■ Service kit for dryer condensate drain (unit with dryer) ■ Change the filter panel ■ Replace the line after filter (change the filter cartridge at least once a year if fitted) Only VSD ■ Replace the filters of electrical cabinet door
Every 8000 hours (or at least every 3 years)	<ul style="list-style-type: none"> ■ ■ Intake service kit ■ ■ Check status of oil return valve and oil pipes ■ ■ Service kit for minimum pressure valve and thermostatic valve ■ ■ Service kit for non-return valve
Every 20000 hours	<ul style="list-style-type: none"> ■ ■ Air-end overhaul kit ■ ■ Service kit Motor (bearings)

N.B.: THE OPERATIONS MARKED ■ ARE DESCRIBED IN PART "A" OF THIS MANUAL ON CHAPTER 15.2

22.0 REPLACING OIL AND OIL FILTER

BEFORE PERFORMING ANY MAINTENANCE, JOBS IT IS MANDATORY TO STOP THE MACHINE AND DISCONNECT IT FROM THE POWER MAINS AND FROM THE COMPRESSED AIR DISTRIBUTION NETWORK.

Oil replacing is an important operation for the compressor: if the lubrication of the bearings is not efficient, the life expectancy of the compressor will be significantly reduced.

The oil must be changed when the machine is still warm, that is immediately after stopping it.

The suggestions listed below should be scrupulously followed.

After draining the old oil out of the machine Ref. 2 Fig. 26.

- Remove the oil filter Ref. 7 Fig. 26
- Lubricate the filter seals with a little oil before fitting.
- Tightening must be done by hand.
- Completely fill the oil collector Ref. 1 Fig. 26.
- Remove the pipe Ref. 3 Fig. 26
- Pour a little oil into the suction unit.
- Reassemble the pipe Ref. 3 Fig. 26
- Start the compressor.
- After about 1-minute switch off the machine by pressing "STOP" (Ref. 4 Fig. 26) after idle time running the machine will switch off.

PROCEED AS DESCRIBED AT POINT CHAPTER 15.4

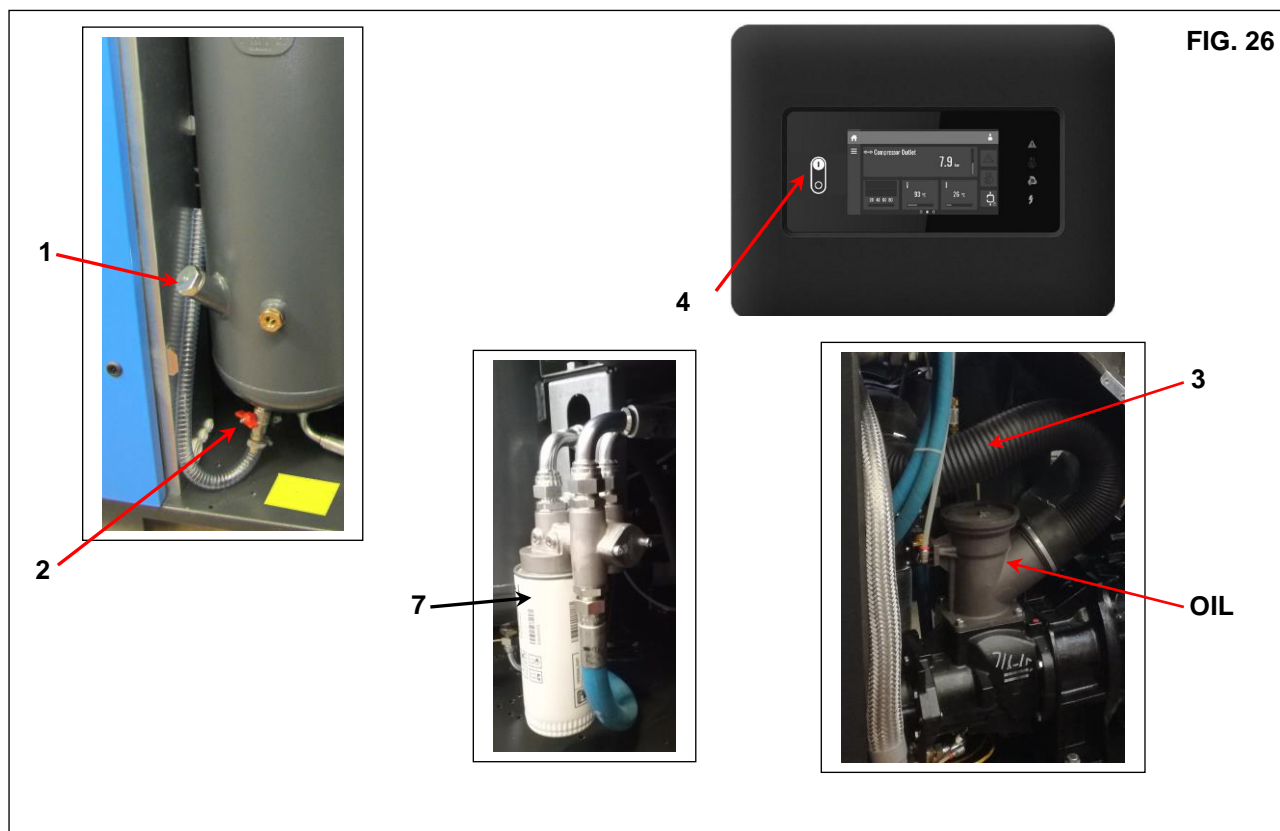

THE OLD OIL MUST BE DISPOSED OF IN COMPLIANCE WITH THE REGULATIONS IN FORCE.

NOTE ON LUBRICANTS

When delivered the machine is filled with oil.

Extending the use of the oil over the scheduled replacement interval result in the risk of fire. If the compressor is used at high temperatures or in particularly severe conditions, we advise shorter oil replacement interval.

DO NOT TOP UP WITH DIFFERENT OILS

23.0 REPLACING OIL SEPARATOR FILTER



BEFORE PERFORMING ANY MAINTENANCE, THE MACHINE MUST BE STOPPED, CUT OFF THE MACHINE FROM THE ELECTRICAL MAINS AND FROM THE COMPRESSED AIR DISTRIBUTION CIRCUIT, CHECK THAT THE MACHINE IS NOT UNDER PRESSURE.

REPLACING Oil SEPARATOR FILTER

Before proceeding with the replacement of the de-oiler filter or the oil filter check that there is no pressure in the machine: check the pressure gauge Ref. 1 Fig. 27.

- Switch off the machine press Ref. 2 Fig. 27: in this way the machine stops after idle time running
- Disconnect the power supply by means of the disconnecter switch, Ref. 3 Fig. 27 for screw-compressor and for the dryer if fitted.
- Disconnect the unit from compressed air network Ref. 5 Fig. 27
- **Check there is no pressure inside the machine : check the pressure gauge Ref. 1 Fig. 27.**
- Remove the oil separator cover Ref. 6 Fig. 27
- Replace oil separator filter and gasket.
- Moisturise gaskets with oil.

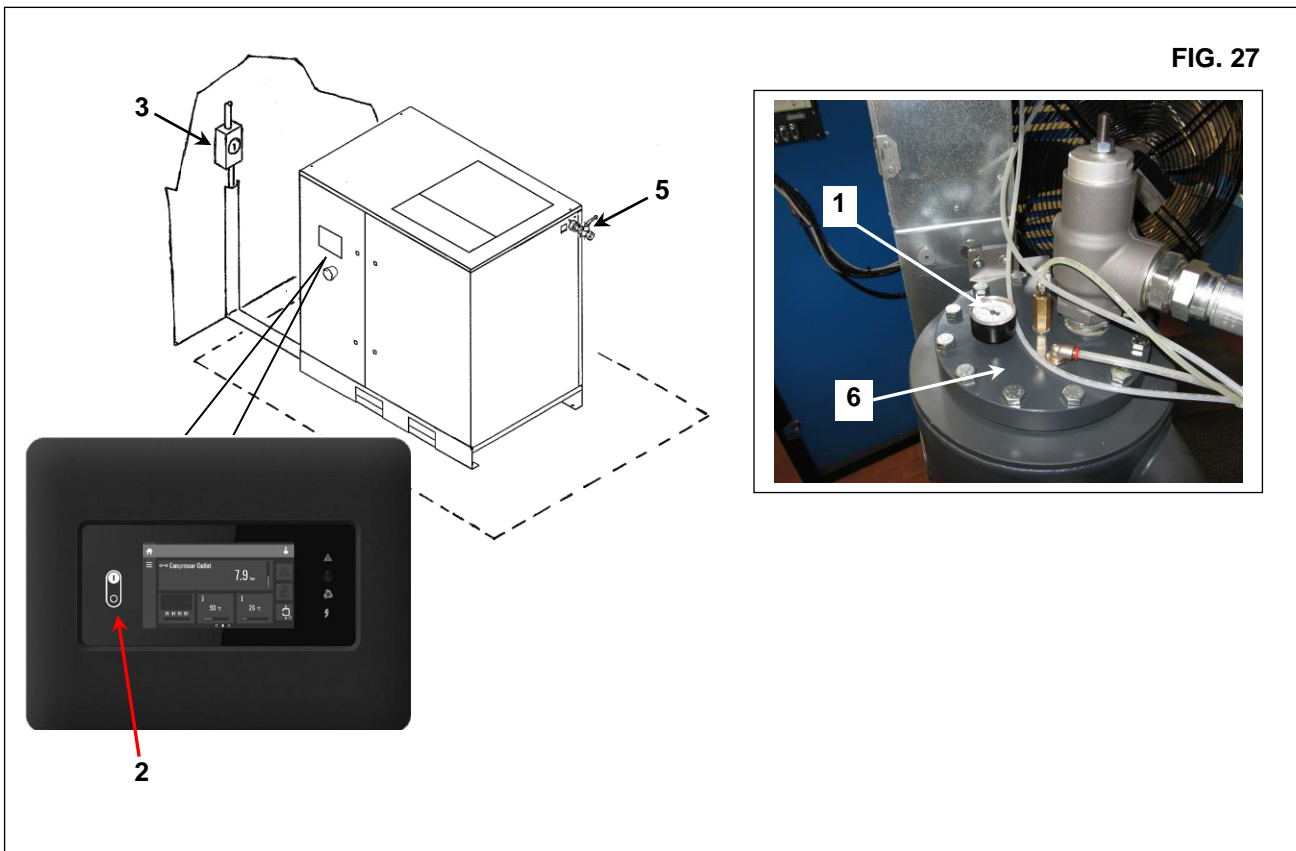

24.0 MOTOR BEARING LUBRICATION;



BEFORE PERFORMING ANY MAINTENANCE THE MACHINE MUST BE STOPPED (See Ref 4 Fig 28), DISCONNECT THE MACHINE FROM THE ELECTRIC SUPPLY AND FROM THE COMPRESSED AIR DISTRIBUTION CIRCUIT, CHECK THAT THE MACHINE IS NOT UNDER PRESSURE.

LUBRIFICATION WITH GREASE BLISTERS

- Remove back panel (fixed protection) Ref. 1 Fig. 28
- Remove greasing nipples Ref. 2 and 3 Fig. 28
- Secure grease blister to motor thread.
- Transfer all grease to the bearing and re-tighten the grease nipples (Ref. Table Fig.28).
- Close the panel (fixed protection) Ref. 1 Fig. 28

FIG. 28

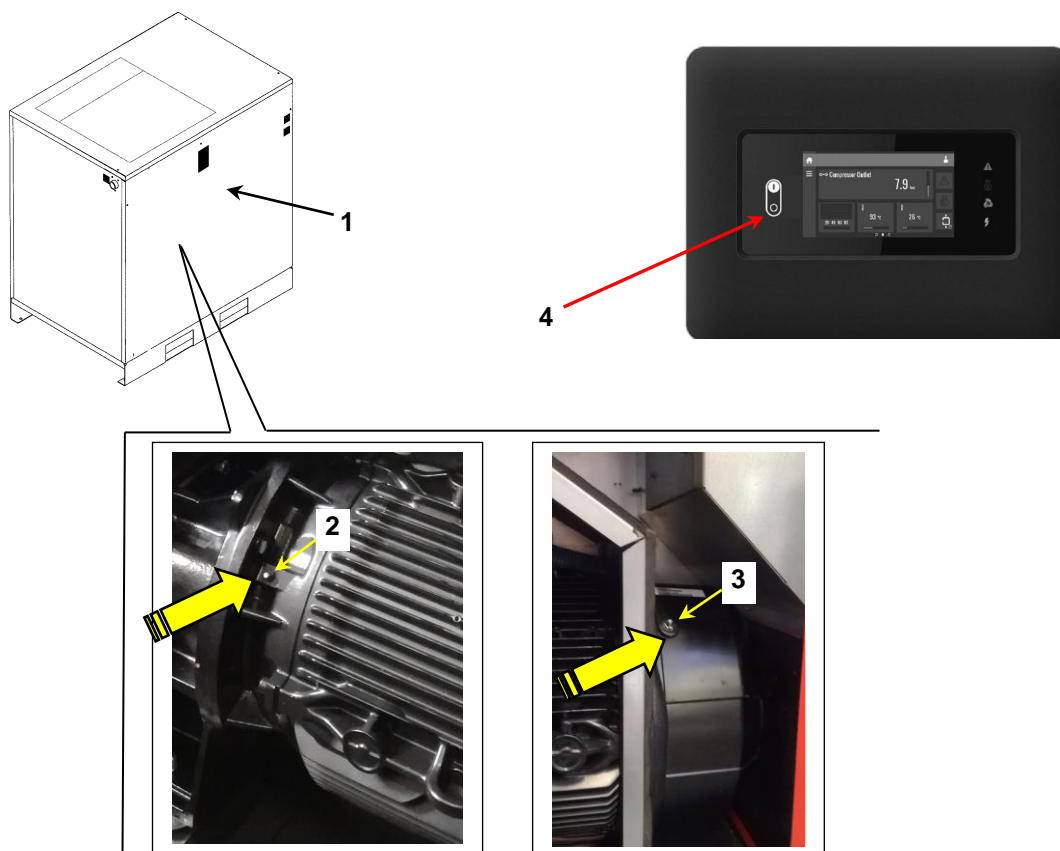

Grease: 1630 2023 00 GREASE SCREWG.SLIDE AMBER 8G			
	(quantity of 20 grams) (Ref. 2) DE	(quantity of 15 grams) (Ref. 3) NDE	
Motor HP 40-50-60	■	■	

24.1 MOTOR BEARING LUBRICATION; (ONLY VSD)



BEFORE PERFORMING ANY MAINTENANCE THE MACHINE MUST BE STOPPED (See Ref 4 Fig 28a), DISCONNECT THE MACHINE FROM THE ELECTRIC SUPPLY AND FROM THE COMPRESSED AIR DISTRIBUTION CIRCUIT, CHECK THAT THE MACHINE IS NOT UNDER PRESSURE.

LUBRIFICATION WITH GREASE BLISTERS

- Remove back panel (fixed protection) Ref. 1 Fig. 28a
- Remove greasing nipples Ref. 2 and 3 Fig. 28a
- Secure grease blister to motor thread.
- Transfer all grease to the bearing and re-tighten the grease nipples (Ref. Table Fig.28a).
- Close the panel (fixed protection) Ref. 1 Fig. 28a

FIG. 28a

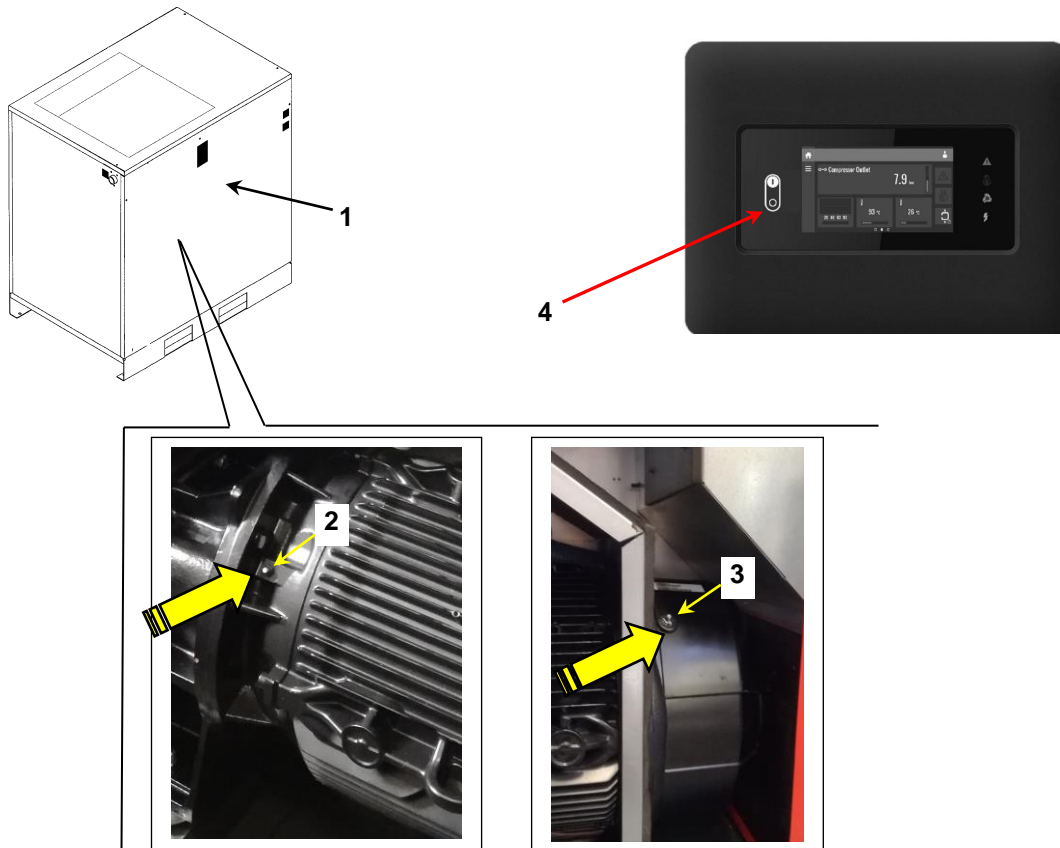

Grease: 1630 2023 00 GREASE SCREWG.SLIDE AMBER 8G			
	(quantity of 24 grams) (Ref. 2) DE	(quantity of 16 grams) (Ref. 3) NDE	
Motor HP 40-50-60	■	■	

24.2 MOTOR BEARING LUBRICATION FOR TOUCH CONTROLLER; (ONLY VSD)

After the new grease injection it's necessary to perform the re-greasing process.

Proceed as follows:

- Restore main power
- Enable lubrication program on MK5 Touch as below:
 - Enable "Advance" access level pushing first the top right corner of display (see 1 below) and then the "Advanced" icon (2).

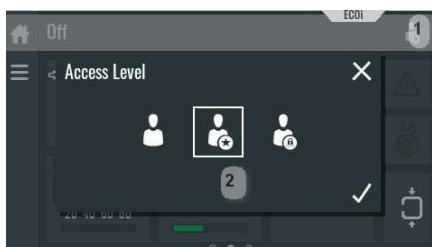

- Select "Main menu", then "Service menu", then "Service function and in the end "Re-greasing".
- Insert activation password (1807)

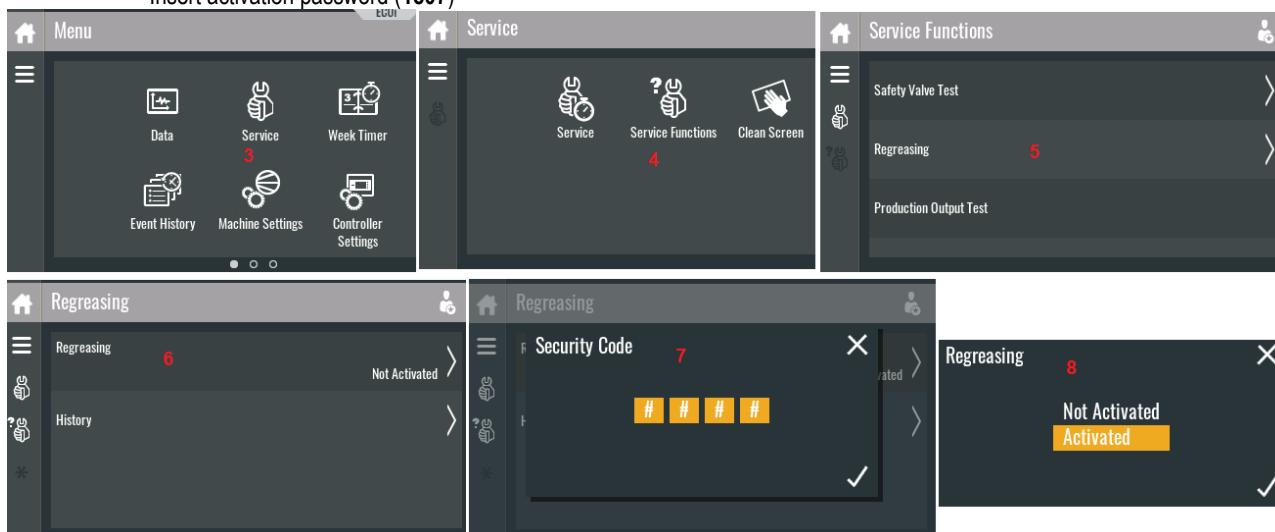

- Go back to main menu. **If the function has been activated the service icon is light on.**



- Now press Start, the compressors will perform the re-greasing cycle in unload (15 minutes at 1700 rpm).
- It's possible to check the re-greasing residual time pushing on "Service" icon.

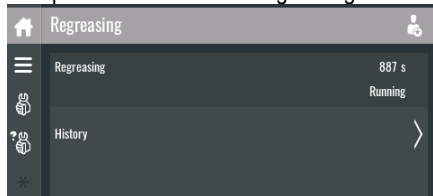

- During re-greasing it is possible to stop the unit pressing "STOP" button.
- Then it's possible to restart it for the residual time.
- At the end of the re-greasing cycle the standard operating conditions will be automatically restored.

24.3 MOTOR BEARING LUBRICATION FOR SWIPE PLUS CONTROLLER; (ONLY VSD)

Proceed as follows:

- Restore main power
- Enable lubrication program on Swipe Plus Controller as explained below:
 - Enable "Service Access" level (use password **2801**): Swipe down 2 times then then left one time then up ... then insert password

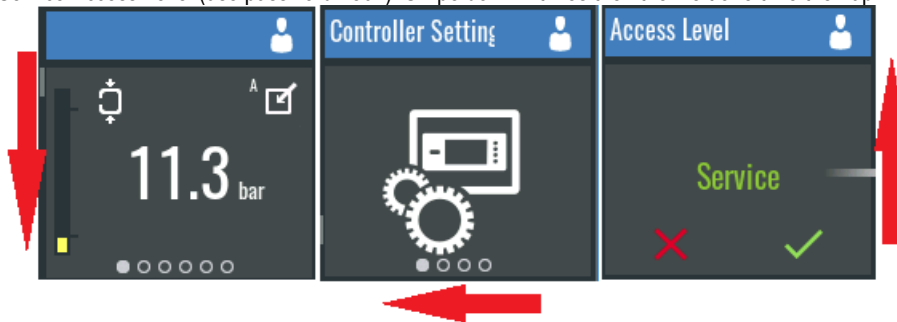

- Swipe down until "Service" Icon is shown then left 4 time until Re-greasing menu is shown.
- Insert password (**1807**) to enable the Re-greasing procedure.
- If the Re-greasing procedure has been correctly activated the "service" Icon will blink on the controller screen.

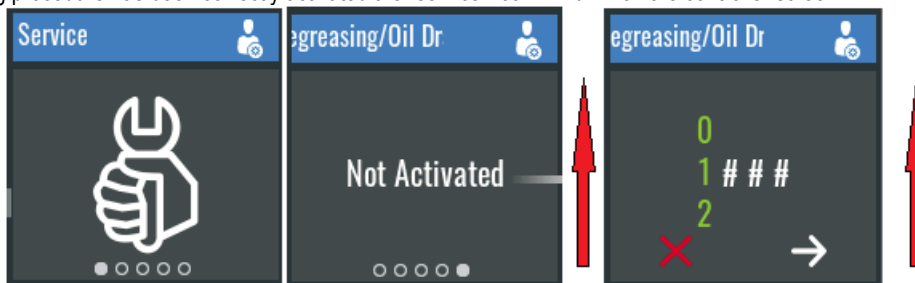

- Go back to main menu and press start button.
- Compressor will perform the Re-greasing cycle: works in unload (15 minutes at 1700 rpm).
- During Re-greasing it is not possible to stop the unit
- The only way the operator can "STOP" the unit is by pressing emergency "STOP".
- Once reset is done the machine can restart and will complete the Re-greasing cycle automatically.
- During the Re-greasing process it's possible to see the residual time: enter in the Re-greasing menu as shown above.

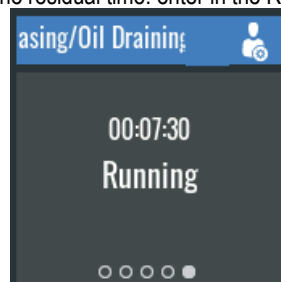

- At the end of the Re-greasing cycle the standard operating conditions will be automatically restored.

25.0 OLEOPNEUMATIC DIAGRAM

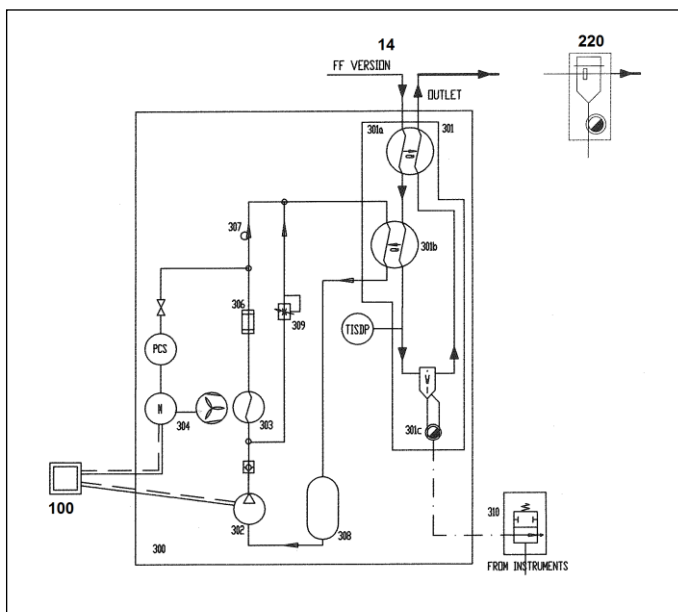
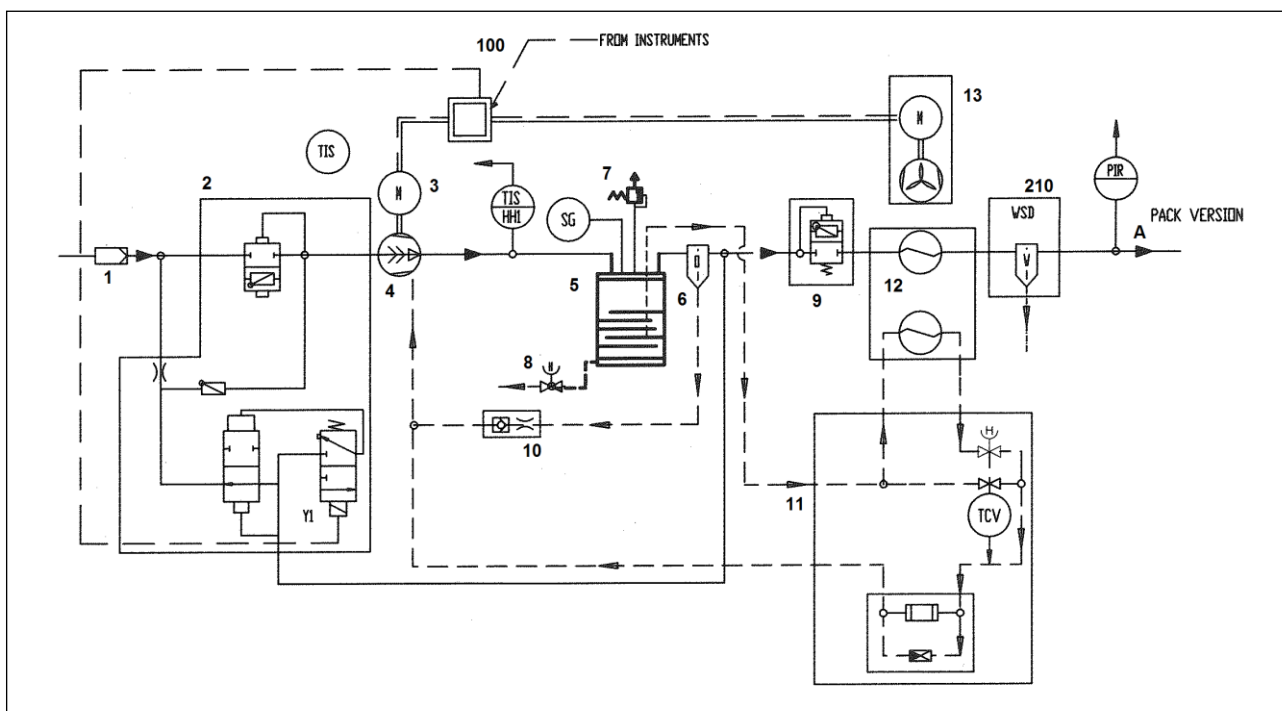

1 INLET FILTER	12 COMBI-COOLER
2 INLET VALVE	13 FAN
3 ELECTRIC MOTOR	14 REFRIGERANT DRYER
4 AIR END	100 CONTROL PANEL
5 OIL VESSEL	210 OPTIONAL WATER SEPARATOR
6 OIL SEPARATOR	220 OPTIONAL LINE FILTER
7 SAFETY VALVE	
8 OIL DRAIN	
9 MINIMUM PRESSURE VALVE	
10 CHECK VALVE	
11 THERMOSTATIC VALVE	

26.0 CALIBRATION FOR DRYER

HOT GAS BYPASS VALVE

N.B. These valves are calibrated at the factory. A different dew point (from rated) may be related to different cause than HGBP.

- 1) Closing cap
- 2) Adjusting screw

WORKING PRESSURE AND TEMPERATURE OF R134a / R410A

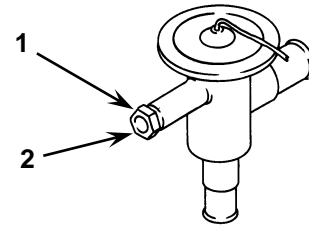

	SUCTION SIDE OF REFRIGERATION COMPRESSOR		
	Evaporat. Temperat. °C (°F)	Evaporating Pressure bar (psi)	
RATED VALUES (Temperat. 20 °C) (68 °F)	1 ÷ 2 (33.8 ÷ 35.6)	R134a 2.1 ÷ 2.3 (30.4 ÷ 33.3)	R410A 7.28 ÷ 7.55 (105.6 ÷ 109.5)

26.1 FLOW DIAGRAM OF THE DRYER

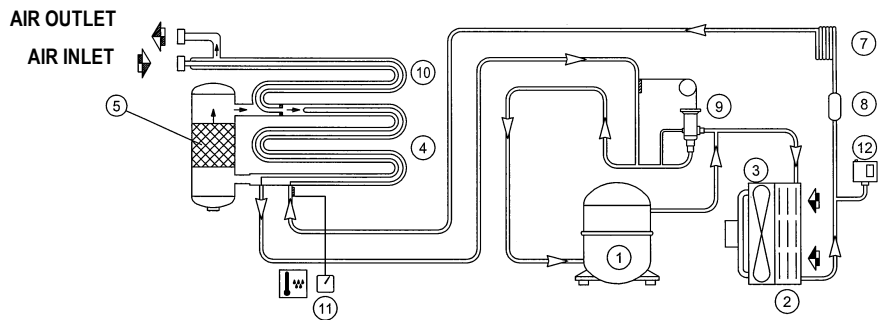

1 COMPRESSOR	8 REFRIGERANT FILTER
2 CONDENSER	9 HOT GAS BYPASS VALVE
3 MOTOR FAN	10 AIR-TO-AIR EXCANGER
4 EVAPORATOR	11 DEW POINT THERMOMETER
5 SEPARATOR	12 FAN PRESSURE SWITCH
7 EXPANSION CAPILLARY TUBE	

27.0 "IVR" VARIABLE SPEED

The "Variable speed" version of the machine is controlled by a frequency converter.

The equipment is configured at the factory and no adjustments to parameters are required.

The modulating pressure is set at 0.5 bar lower than maximum pressure: depending on the air demand, the frequency converter varies the motor speed. To meet the air demand of the customer network.

SETTING THE MODULATION PRESSURE

The compressor modulating pressure is set at 0.5 bar less than maximum pressure. By changing the adjustment value also change the value of the maximum pressure.

