

Model name	LZB42_AR_3_11	Rev. Ver	0.1
Drawing name	LZB42_AR_3_11	Rev. Ver	0.1

This document and its content is the intellectual property of Atlas Copco Industrial Technique AB. Any use, including but not limited to reproduction, distribution, publication, modification and copying without prior written authorization is strictly prohibited.

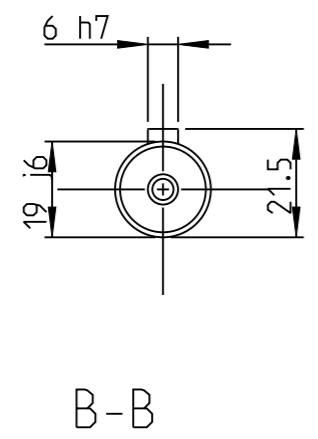
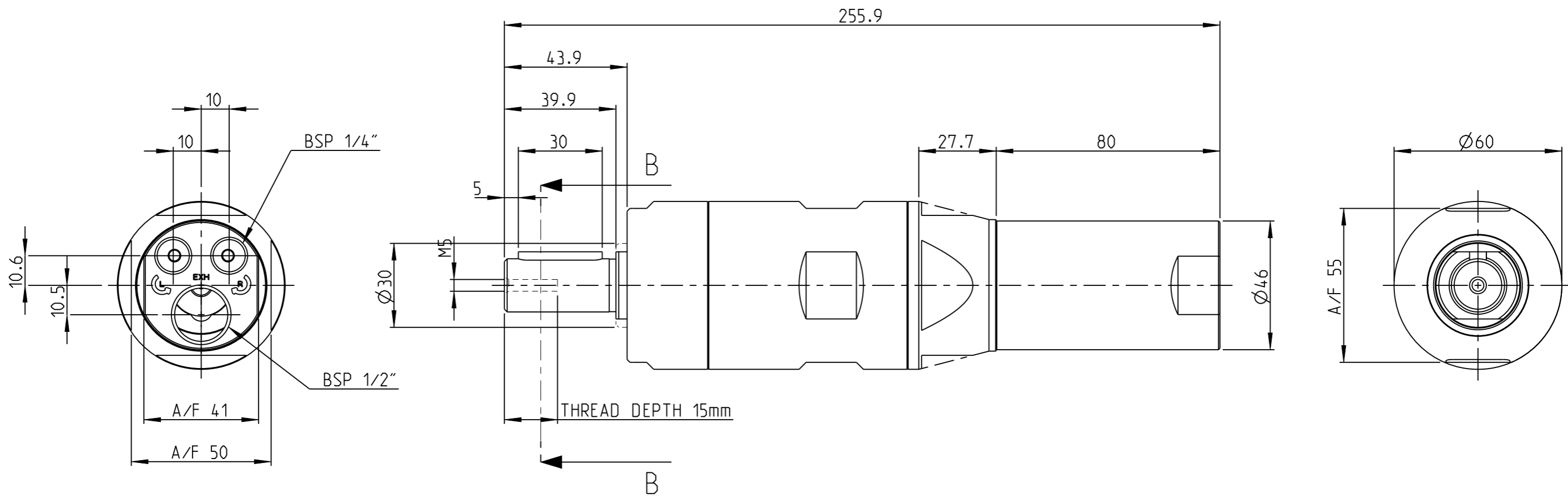

MOTOR NAME	ORDERING NO.
LZB42-L-AR0025-11	8411 0423 70
LZB42-L-AR0015-11	8411 0423 88
LZB42-L-AR0010-11	8411 0423 96

Note	Pos.	Modified from	Date	Intr.
0	-	-	-	-

Tolerances, if not indicated, according to:		-	-	-	-	-
AC-STD		-	-	-	-	-
Name VANE MOTOR LZB42-L-ARXXX-11					LZB42-AR	
Material -					Secrecy class 1102 K/-	
-					CAD Pro/E	
Scale 2:3		Format A3		Family -		Drawing owner TOO
Drawn F GRINELL		Blank -		Compare -		
Transferred from -		Cons.class 1295 K/-		Rev 0		Designation LZB42_AR_3_11
Mass/Volume -		Status In Work		Date 2013-05-02		

A
B
C
D
E
F
G