

Model name	TZB25_L_1_15	Rev. No.	0.2
Drawing name	TZB25_L_1_15	Rev. No.	0.2

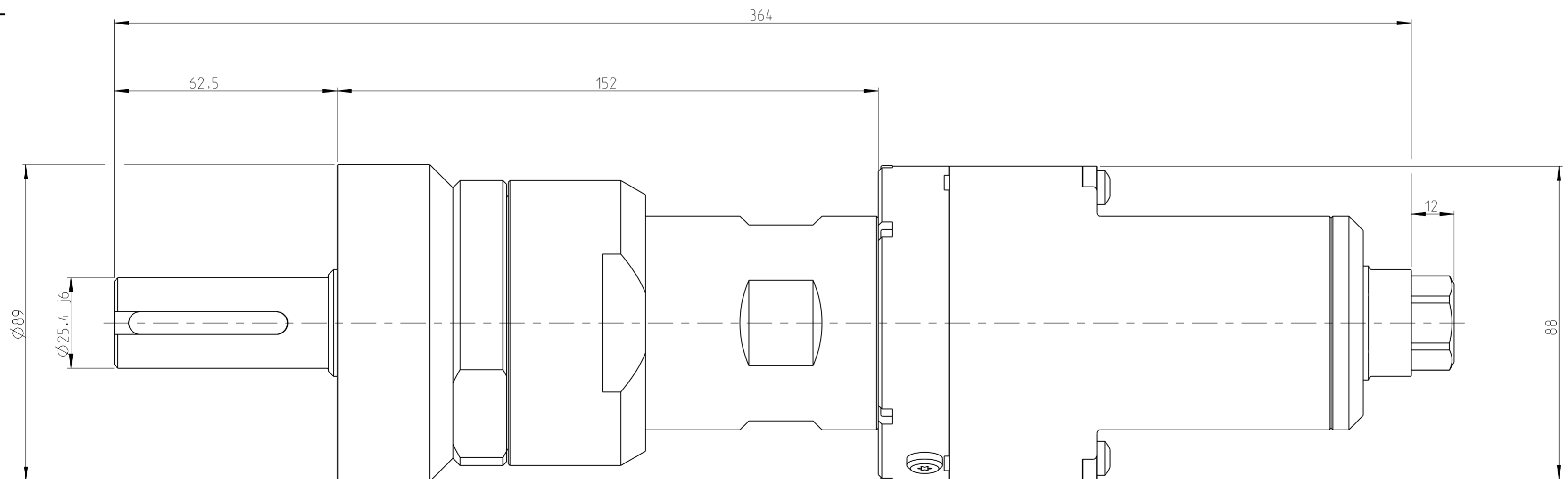
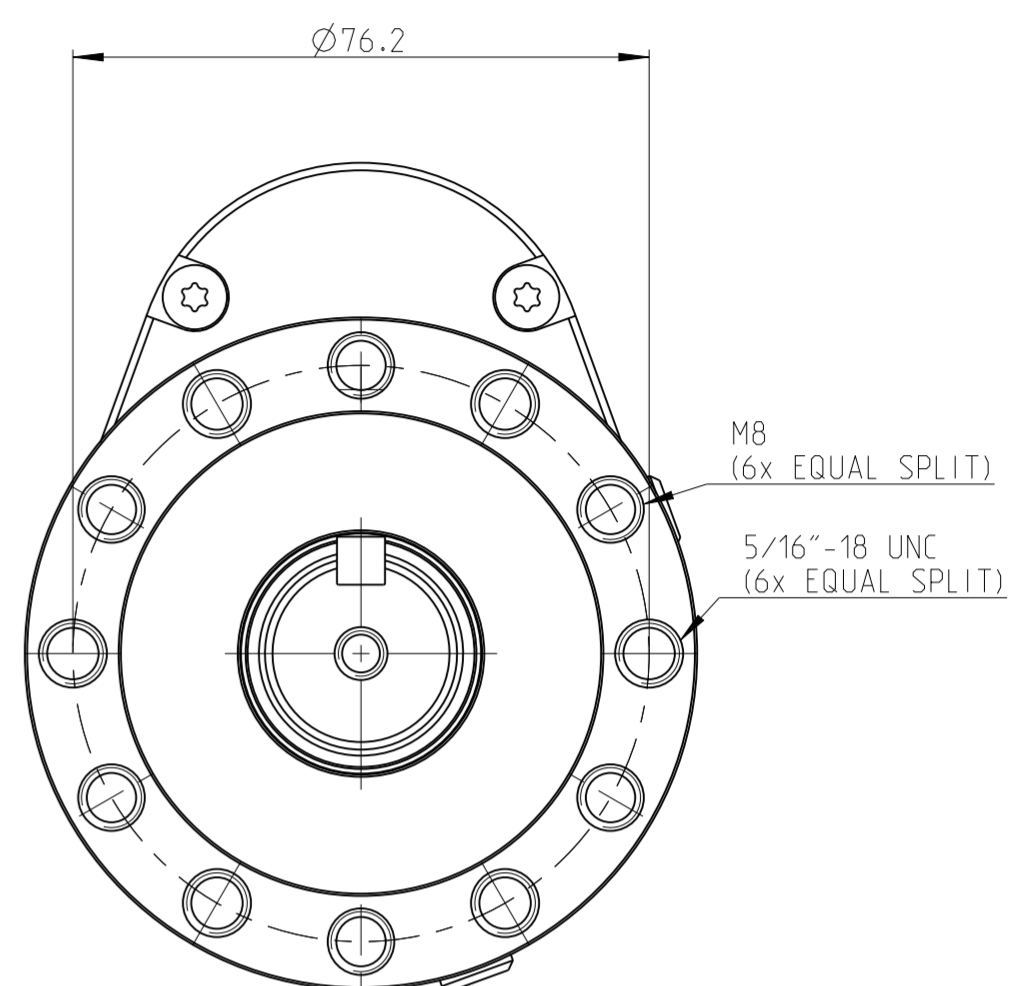
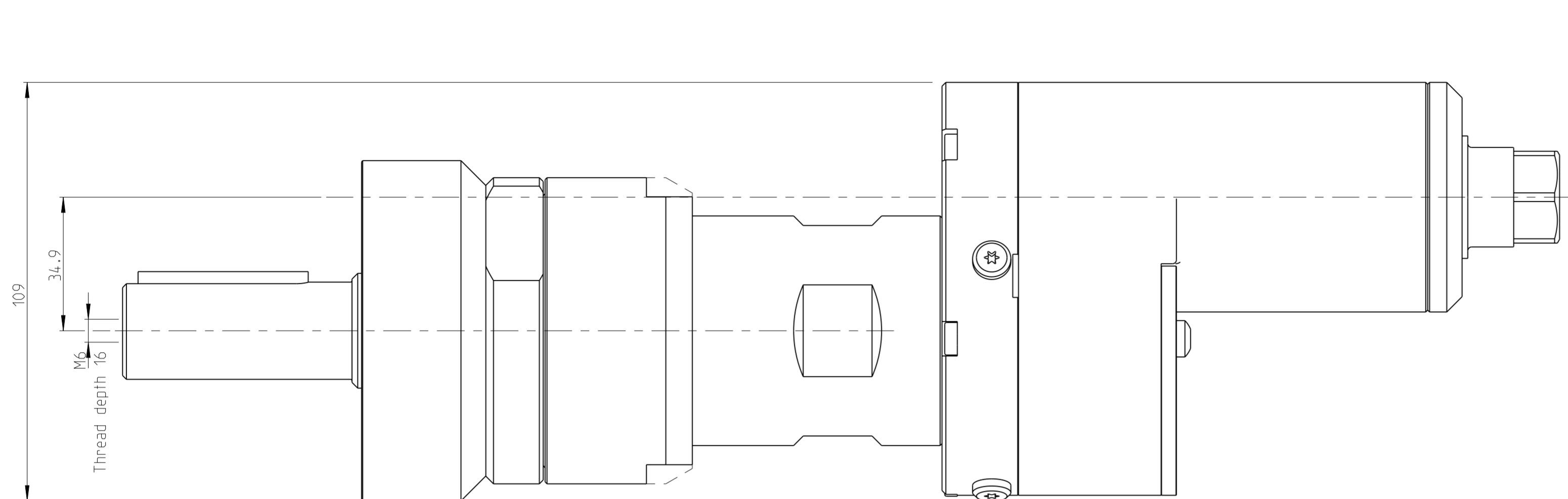

Motor name	Ordering no.
TZB25-L-A0008-15	8411 3100 17
TZB25-L-A0012-15	8411 3100 25
TZB25-L-AV0008-15	8411 3100 58
TZB25-L-AV0012-15	8411 3100 66

This document is our property and shall not without our permission be altered, copied, used for manufacturing or communicated to any other person or company.

Note	Pos.	Modified from	Date	Intr.
0	-	-	-	-

Tolerances, if not indicated, according to:		-	-	-	-	-	
AC-STD		-	-	-	-	-	
Name	TZB25-L-XX-XXXXXX-15			TZB25	Secrecy class		
Material	-			1102 K/-		Drawing owner	
	-			CAD Pro/E			
	Scale	1:1	Format	A2	Family	-	
	Drawn	P. Horvath		Blank	-	Replaces	-
Transferred from	Cons.class	1295 K/-	Rev	0	Status	In Work	
	Mass/Volume	-	Date	2019-01-28		Designation	TZB25_L_1_15
						Sheet 1 (1)	T00