

Model name	TZB25_L_2_14	Rev. No.	0.2
Drawing name	TZB25_L_2_14	Rev. No.	0.2

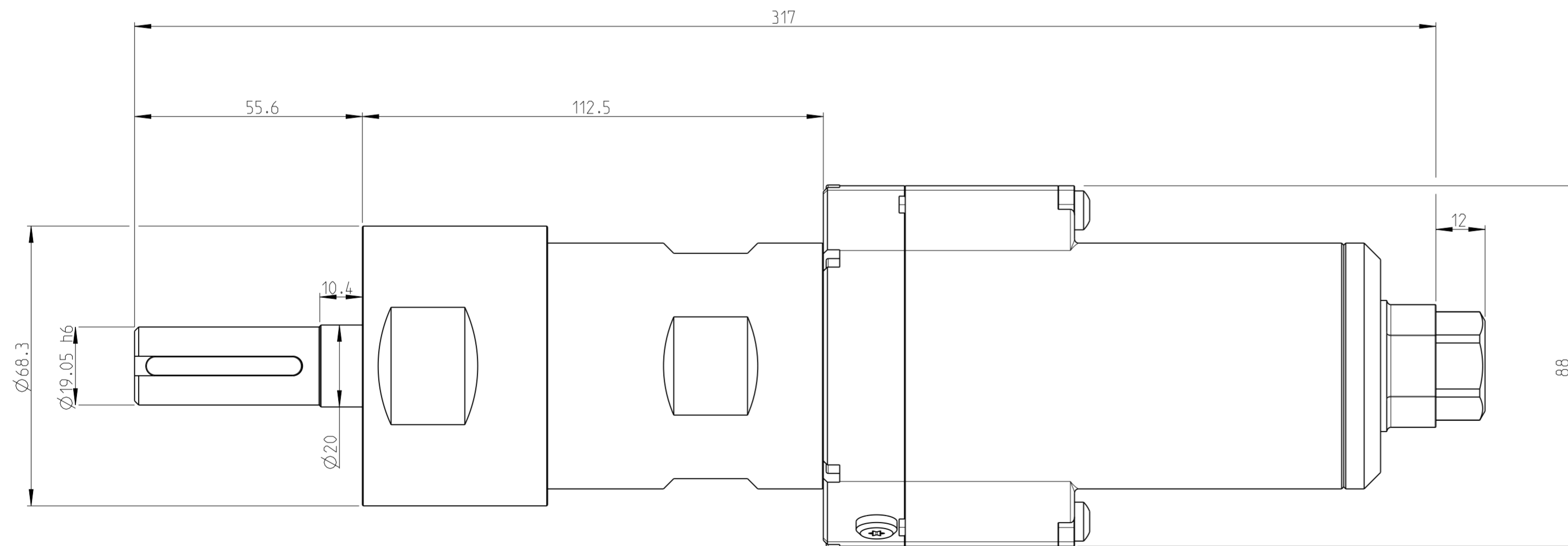
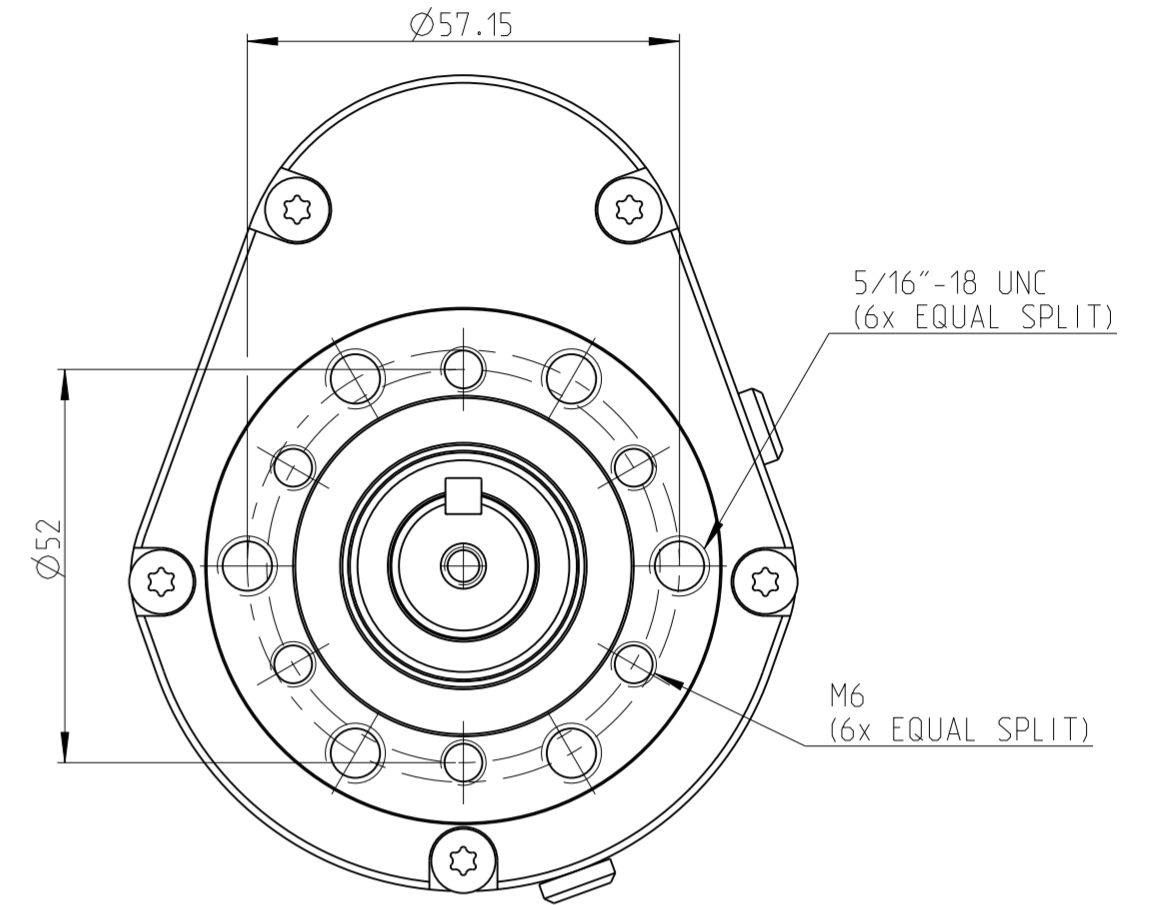
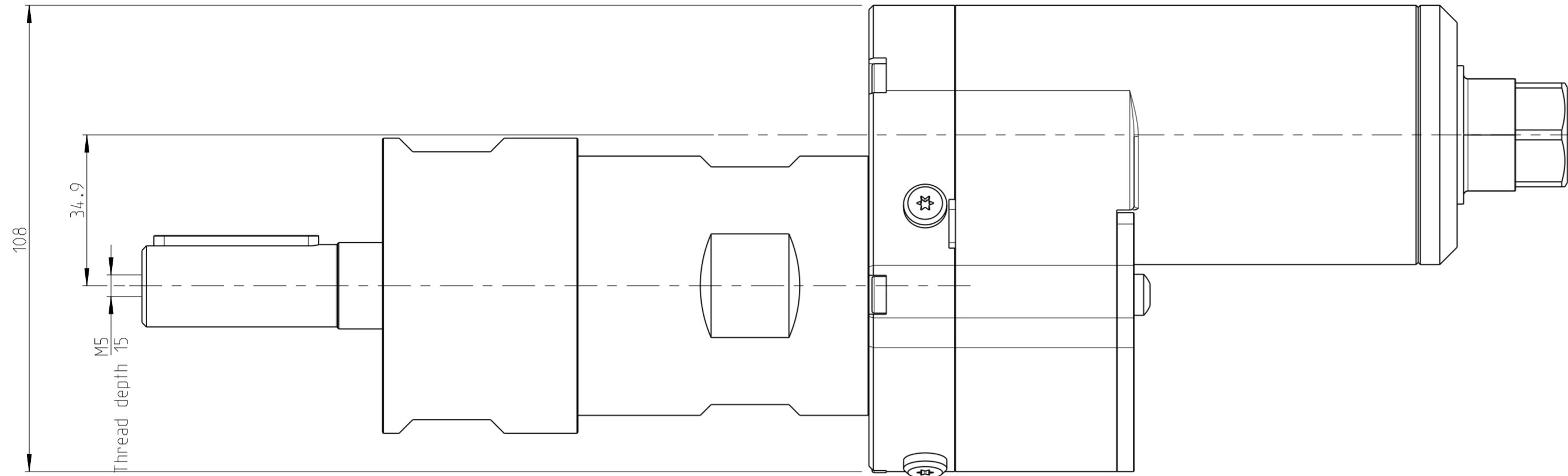

Motor name	Ordering no.
TZB25-L-A0032-14	8411 3100 32
TZB25-L-A0050-14	8411 3100 40
TZB25-L-AV0032-14	8411 3100 73
TZB25-L-AV0050-14	8411 3100 81

This document is our property and shall not without our permission be altered, copied, used for manufacturing or communicated to any other person or company.

Note	Pos.	Modified from	Date	Intr.
0	-	-	-	-

Tolerances, if not indicated, according to:		-	-	-	-	-	
AC-STD		-	-	-	-	-	
Name	TZB25-L-XX-XXXXXX-14		TZB25	Secretcy class			
Material	-		1102 K/-		Drawing owner		
-		CAD	Pro/E		TOO		
	Scale	1:1	Format	A2	Family	-	
	Drawn	P. Horvath		Blank	-	Replaces	-
Transferred from	Cons.class	1295 K/-	Rev	0	Status	In Work	
-	Mass/Volume	-	Date	2019-01-28		Designation	TZB25_L_2_14
						Sheet 1 (1)	