

Model name LZL25-BF322-B Rev.Ver 0.1
 Drawing name LZL25-BF322-B Rev.Ver 0.1

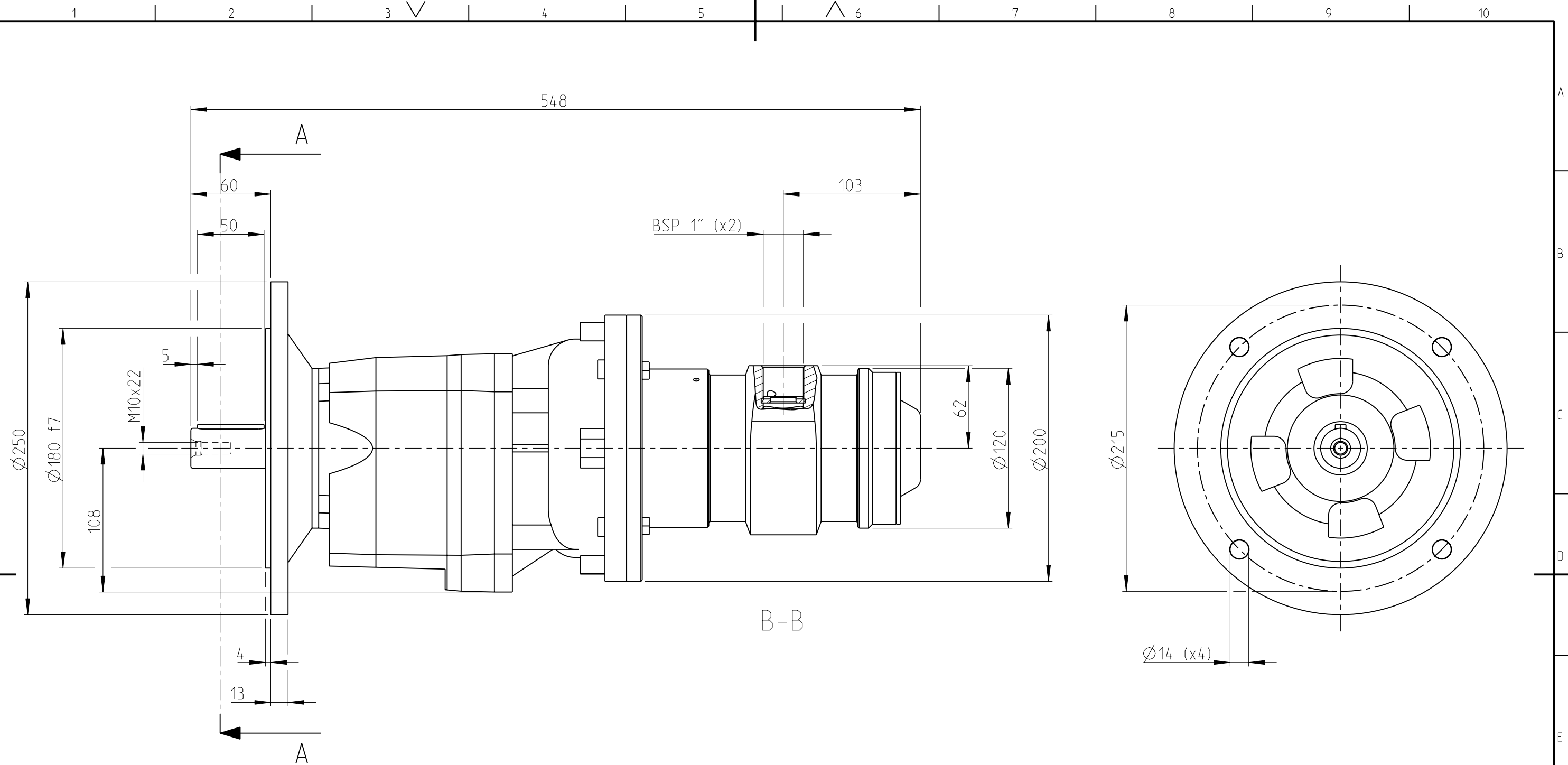

MOTOR NAME	ORDERING NO.
LZL25-BF322-B-011	8411 1811 94
LZL25-BF322-B-018	8411 1812 10

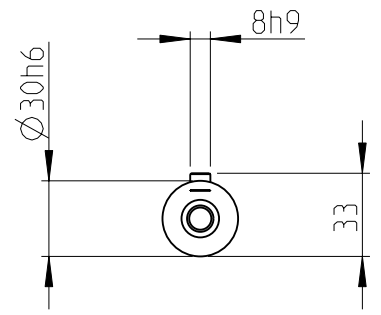

A-A

Tolerances, if not indicated, according to:		-	-	-	-	-
AC-STD		-	-	-	-	-
Name LZL25-BF322-B					Secrecy class	
Material -					1102 K/-	
-					CAD Pro/E	
Scale 1:3		Format A3	Family -	Compare -		Drawing owner TOO
Drawn F GRINELL		Blank -	Replaces -			
Transferred from -		Cons.class 1295 K/-	Rev 0	Status In Work	Designation LZL25-BF322-B	
		Mass/Volume -	Date 2013-05-30	Sheet 1 (1)		

This document is our property and shall not without our permission be altered, copied, used for manufacturing or communicated to any other person or company.

Note	Pos.	Modified from	Date	Intr.
0	-	-	-	-