

Model name LZB78\_AR\_1\_15\_00 Rev. No. 0.1  
 Drawing name LZB78\_AR\_1\_15\_00 Rev. No. 0.1

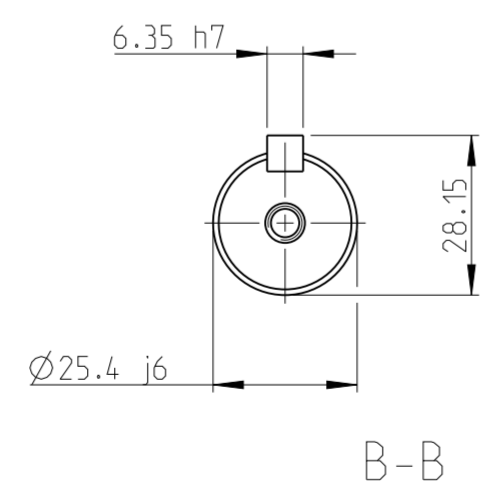
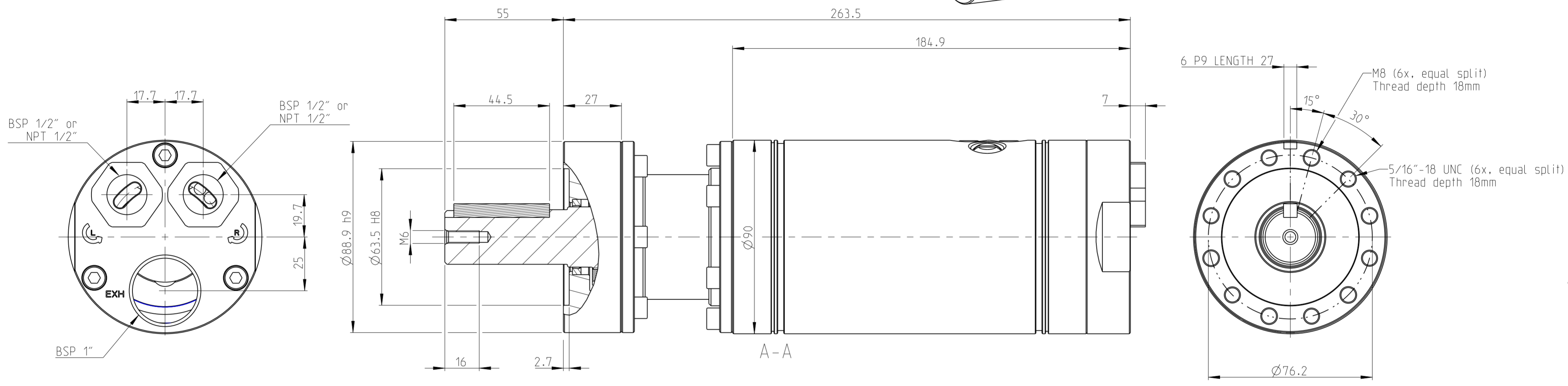
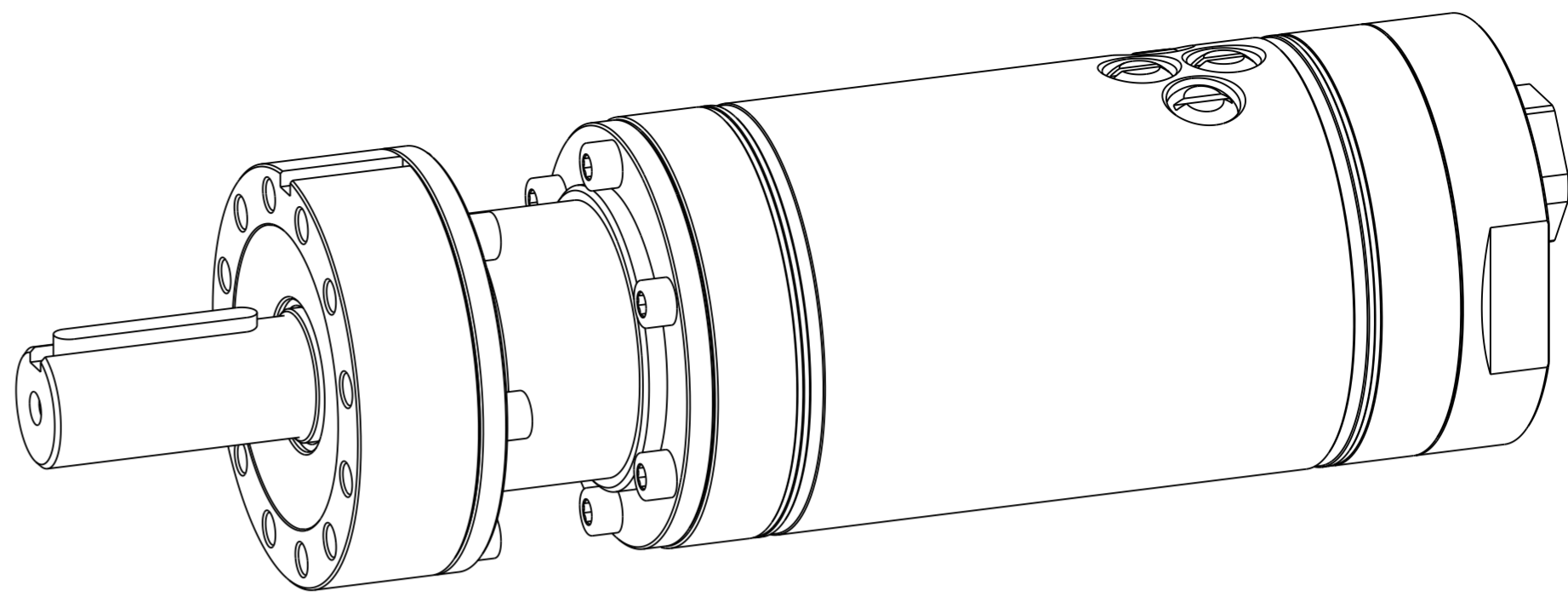

MOTOR NAME	ORDERING NO.
LZB78-L-AR024-15	8411 0702 92
LZB78-L-AR016-15	8411 0703 00
LZB78-L-AR012-15	8411 0703 18

This document and its content is the intellectual property of Atlas Copco Industrial Technique AB. All uses, including but not limited to reproduction, distribution, publication, modification and copying, without prior written authorization is strictly prohibited.

Note	Pos.	Modified from	Date	Intr.
0	-	-	-	-

Tolerances, if not indicated, according to:		-	-	-	-	-	
AC-STD		-	-	-	-	-	
Name	LZB78-L-ARXXX-15		LZB78	Secrecy class			
Material	-		1102 K/-		Drawing owner		
-		CAD			TOO		
	Scale	3:4	Format	A2	Family	-	
	Drawn	A Ödling		Blank	-	Replaces	-
Transferred from	Cons.class	1295 K/-	Rev	0	Status	In Work	
-	Mass/Volume	-	Date	2023-03-21		Designation	LZB78_AR_1_15
						Sheet 1 (1)	